

USER'S MANUAL

HYBRID SOLAR INVERTER 6KW-12KW



Appliances IVT201



PC



TV



Air-
conditioning



Fridge



Washing
machine

CATALOGUE

1. Safety Introductions	01
2. Product instructions	02-04
2.1 Product Overview	
2.2 Product Size	
2.3 Product Features	
2.4 Basic System Architecture	
3. Installation	05-24
3.1 Parts list	
3.2 Mounting instructions	
3.3 Battery connection	
3.4 Grid connection and backup load connection	
3.5 PV Connection	
3.6 CT Connection	
3.6.1 Meter Connection	
3.7 Earth Connection(mandatory)	
3.8 WIFI Connection	
3.9 Wiring System for Inverter	
3.10 Wiring diagram	
3.11 Typical application diagram of diesel generator	
3.12 phase parallel connection diagram	
4. OPERATION.....	25
4.1 Power ON/OFF	
4.2 Operation and Display Panel	
5. LCD Display Icons	26-38
5.1 Main Screen	
5.2 Solar Power Curve	
5.3 Curve Page-Solar & Load & Grid	
5.4 System Setup Menu	
5.5 Basic Setup Menu	
5.6 Battery Setup Menu	
5.7 System Work Mode Setup Menu	
5.8 Grid Setup Menu	
5.9 Generator Port Use Setup Menu	
5.10 Advanced Function Setup Menu	
5.11 Device Info Setup Menu	
6. Mode	38-39
8. Limitation of Liability	42-43
9. Datasheet	43-45
10. Appendix I	46-47
11. Appendix II	48

About This Manual

The manual mainly describes the product information, guidelines for installation, operation and maintenance. The manual cannot include complete information about the photovoltaic (PV) system.

How to Use This Manual

Read the manual and other related documents before performing any operation on the inverter. Documents must be stored carefully and be available at all times.

1. Contents may be periodically updated or revised due to product development. The information in this manual is subject to change without notice.

2. Safety Introductions

Safety signs



The DC input terminals of the inverter must not be grounded.



Surface high temperature, Please do not touch the inverter case.



The AC and DC circuits must be disconnected separately, and the maintenance personnel must wait for 5 minutes before they are completely powered off before they can start working.



Prohibit disassembling inverter case, there existing shock hazard, which may cause serious injury or death, please ask qualified person to repair.



Please read the instructions carefully before use.



Do Not put it in the waste bin! Recycle it by licensed professional!

- This chapter contains important safety and operating instructions. Read and keep this manual for future reference.
- Before using the inverter, please read the instructions and warning signs of the battery and corresponding sections in the instruction manual.
- Do not disassemble the inverter. If you need maintenance or repair, take it to a professional service center.
- Improper reassembly may result in electric shock or fire.
- To reduce risk of electric shock, disconnect all wires before attempting any maintenance or cleaning. Turning off the unit will not reduce this risk.
- Caution: Only qualified personnel can install this device with battery.
- Never charge a frozen battery.
- For optimum operation of this inverter, please follow required specification to select appropriate cable size. It is very important to correctly operate this inverter.
- Be very cautious when working with metal tools on or around batteries. Dropping a tool may cause a spark or short circuit in batteries or other electrical parts, even cause an explosion.
- Please strictly follow installation procedure when you want to disconnect AC or DC terminals. Please refer to "Installation" section of this manual for the details.
- Grounding instructions - this inverter should be connected to a permanent grounded wiring system. Be sure to comply with local requirements and regulation to install this inverter.
- Never cause AC output and DC input short circuited. Do not connect to the mains when DC input short circuits.

3. Product Introductions

This is a multifunctional inverter, combining functions of inverter, solar charger and battery charger to offer uninterruptible power support with portable size. Its comprehensive LCD display offers user configurable and easy accessible button operation such as battery charging, AC/solar charging, and acceptable input voltage based on different applications.

3.1 Product Overview

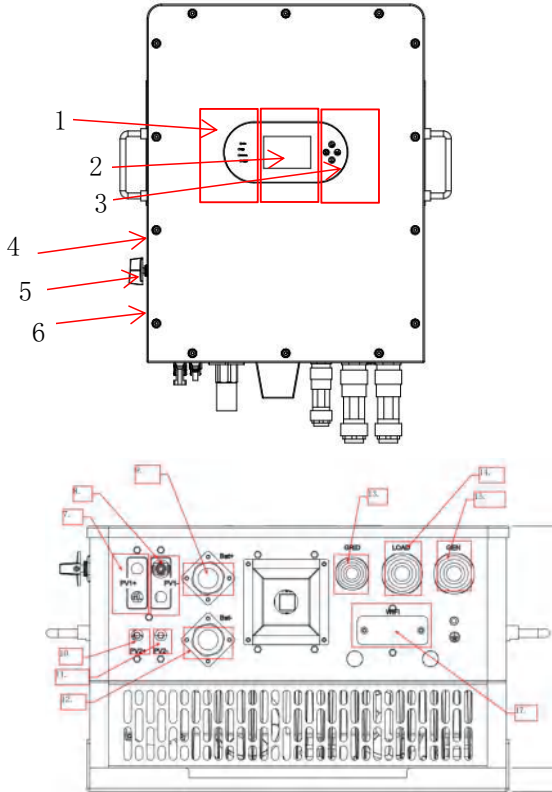

- | | | |
|------------------------|----------|--------------------|
| 1: Inverter indicators | 7: Pv1+ | 13: Grid |
| 2: LCD display | 8: Pv1- | 14: Load |
| 3: Function buttons | 9: Bat+ | 15: Gen |
| 4: Power on/off button | 10: Pv2+ | 16: WiFi Interface |
| 5: PV switch | 11: Pv2- | |
| 6: GRID switch | 12: Bat- | |

*for some hardware versions, the circuit breaker of Grid is not existed

3.2 Product Size

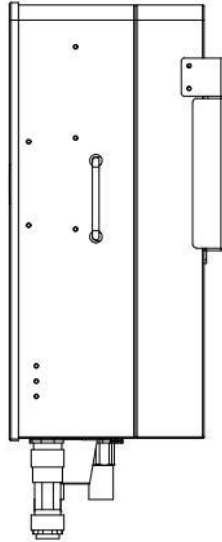
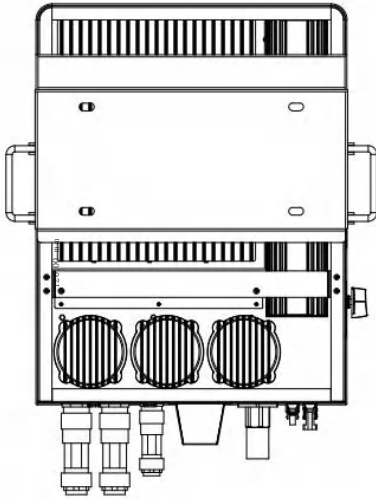
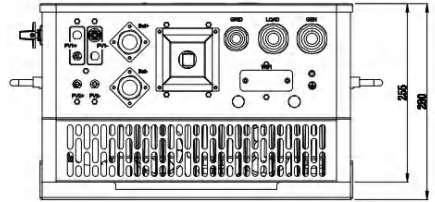
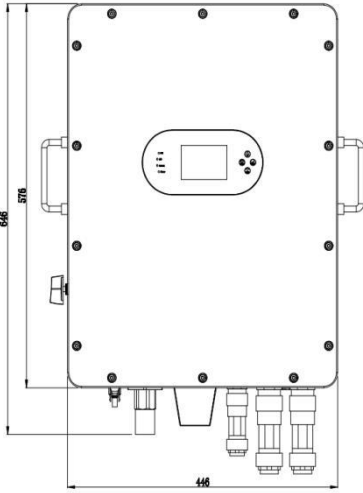

3.3 Product Features

- 230V/400V Three phase Pure sine wave inverter.
- Self-consumption and feed-in to the grid.
- Auto restart while AC is recovering.
- Programmable supply priority for battery or grid.
- Programmable multiple operation modes: On grid, off grid and UPS.
- Configurable battery charging current/voltage based on applications by LCD setting.
- Configurable AC/Solar/Generator Charger priority by LCD setting.
- Compatible with mains voltage or generator power.
- Overload/over temperature/short circuit protection.
- Smart battery charger design for optimized battery performance
- With limit function, prevent excess power overflow to the grid.
- Supporting WIFI monitoring and build-in 2 strings for 1 MPP tracker, 1 string for 1 MPP tracker.
- Smart settable three stages MPPT charging for optimized battery performance.
- Time of use function.
- Smart Load Function.

2.4 Basic System Architecture

The following illustration shows basic application of this inverter. It also includes following devices to have a Complete running system.

- Generator or Utility
- PV modules

Consult with your system integrator for other possible system architectures depending on your requirements.

This inverter can power all kinds of appliances in home or office environment, including motor type appliances such as refrigerator and air conditioner.

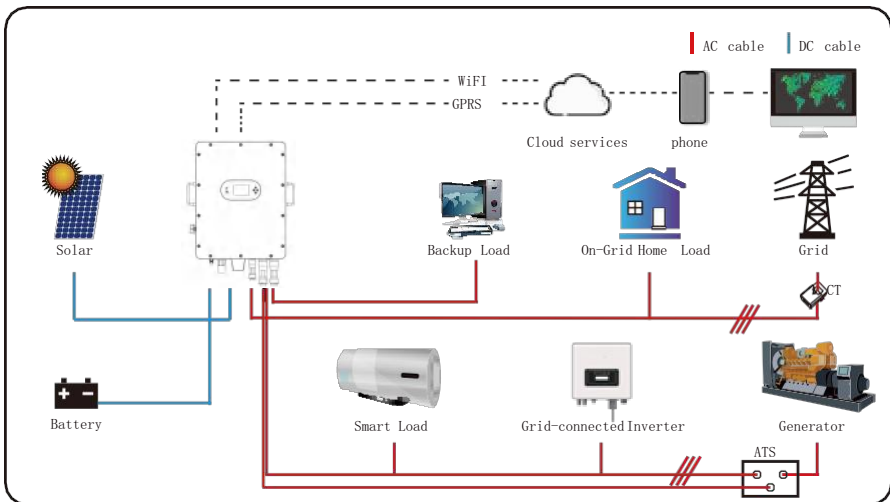

4. Installation

4.1 Parts List

Check the equipment before installation. Please make sure nothing is damaged in the package. You should have received the items in the following package:

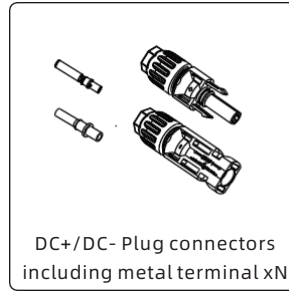
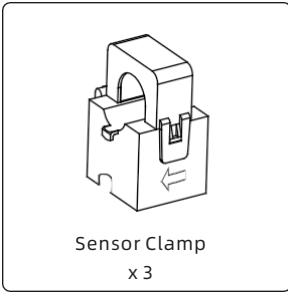
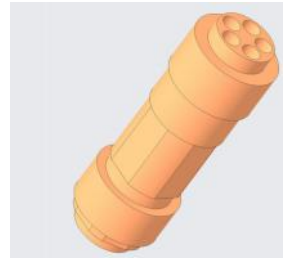
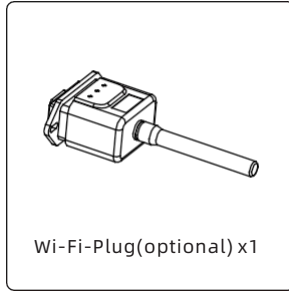
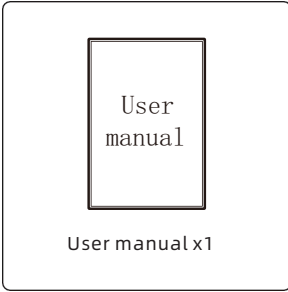
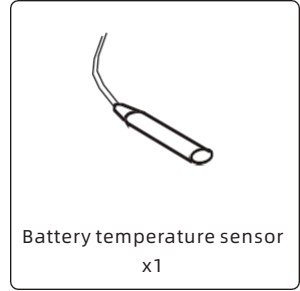
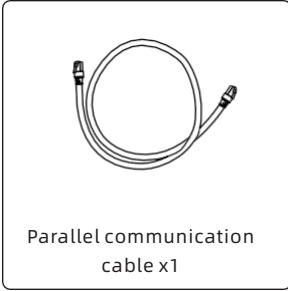
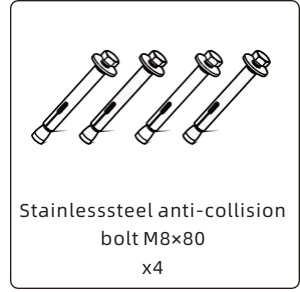
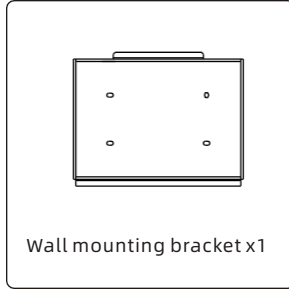
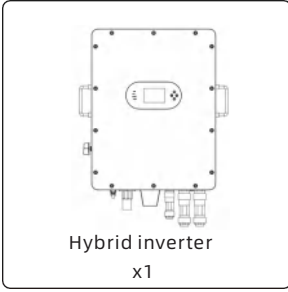

4.2 Mounting instructions

Installation Precaution

This Hybrid inverter is designed for outdoor use(IP65), Please make sure the installation site meets below conditions:

- Not in direct sunlight
- Not in areas where highly flammable materials are stored.
- Not in potential explosive areas.
- Not in the cool air directly.
- Not near the television Antenna or antenna cable.
- Not higher than altitude of about 2000 meters above sea level.
- Not in environment of precipitation or humidity(>95%)

Considering the following points before selecting where to install:

- Please select a vertical wall with load-bearing capacity for installation, suitable for installation on concrete or other non-flammable surfaces, installation is shown below.
- Install this inverter at eye level in order to allow the LCD display to be read at all times.
- The ambient temperature is recommended to be between -40~60℃ to ensure optimal operation.
- Be sure to keep other objects and surfaces as shown in the diagram to guarantee sufficient heat dissipation and have enough space for removing wires.

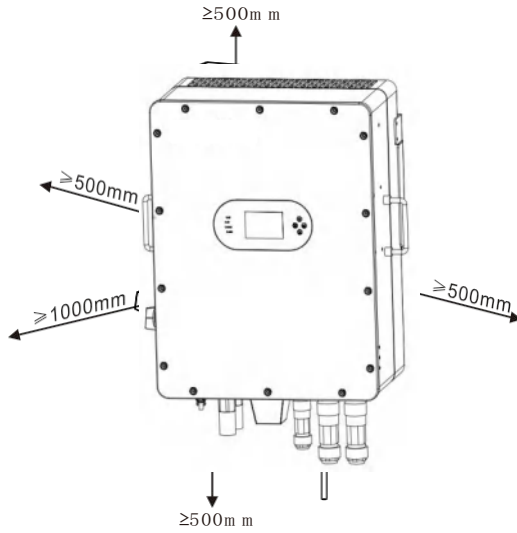

For proper air circulation to dissipate heat, allow a clearance of approx. 50cm to the side and approx. 50cm above and below the unit. And 100cm to the front.

Mounting the inverter

Remember that this inverter is heavy! Please be careful when lifting out from the package. Choose the recommend drill head(as shown in below pic) to drill 4 holes on the wall, 82-90mm deep.

1. Use a proper hammer to fit the expansion bolt into the holes.
2. Carry the inverter and holding it, make sure the hanger aim at the expansion bolt, fix the inverter on the wall.
3. Fasten the screw head of the expansion bolt to finish the mounting.

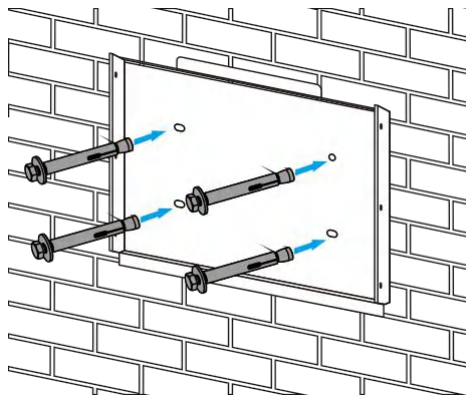

Inverter hanging plate installation

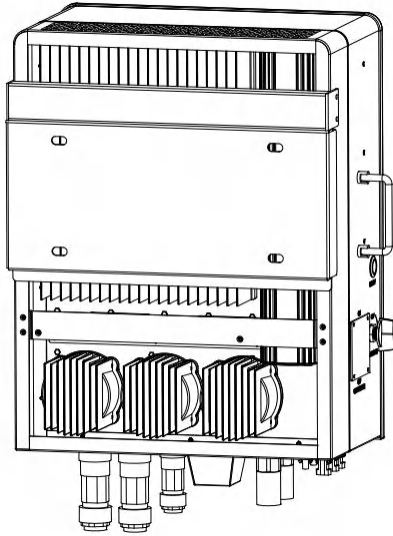

4.3 Battery connection

For safe operation and compliance, a separate DC over-current protector or disconnect device is required between the battery and the inverter. In some applications, switching devices may not be required but over-current protectors are still required. Refer to the typical amperage in the table below for the required fuse or circuit breaker size.

Model	Wire Size	Cable(mm ²)	Torque value(max)
6/8kW	1AWG	42.41	24.5Nm
10/12kW	1/0AWG	53.49	24.5Nm



All wiring must be performed by a professional person.



Connecting the battery with a suitable cable is important for safe and efficient operation of the system. To reduce the risk of injury, refer to Chart 3-2 for recommended cables.

Please follow below steps to implement battery connection:

1. Please choose a suitable battery cable with correct connector which can well fit into the battery terminals.
 2. Use a suitable screwdriver to unscrew the bolts and fit the battery connectors in, then fasten the bolt by the screwdriver, make sure the bolts are tightened with torque of 24.5 N.M in clockwise direction.
 3. Make sure polarity at both the battery and inverter is correctly connected.
- For 5-12kW model, battery connector screw size: M10

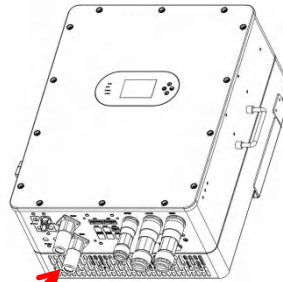

DC Battery Input 2/1AWG Wire Size

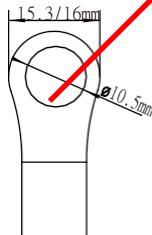

4. In case of children touch or insects go into the inverter, Please make sure the inverter connector is fasten to waterproof position by twist it clockwise.



Installation must be performed with care.



Before making the final DC connection or closing DC breaker/disconnect, be sure positive(+) must be connect to positive(+) and negative(-) must be connected to negative(-). Reverse polarity connection on battery will damage the inverter.

3.3.2 Function port definition

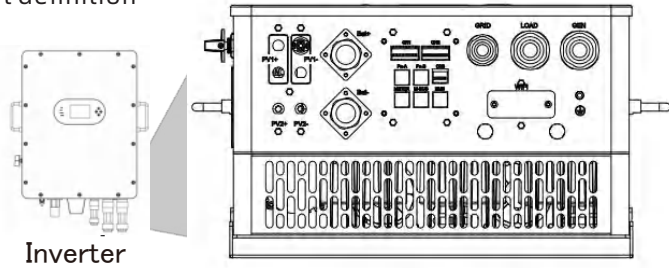

Inverter

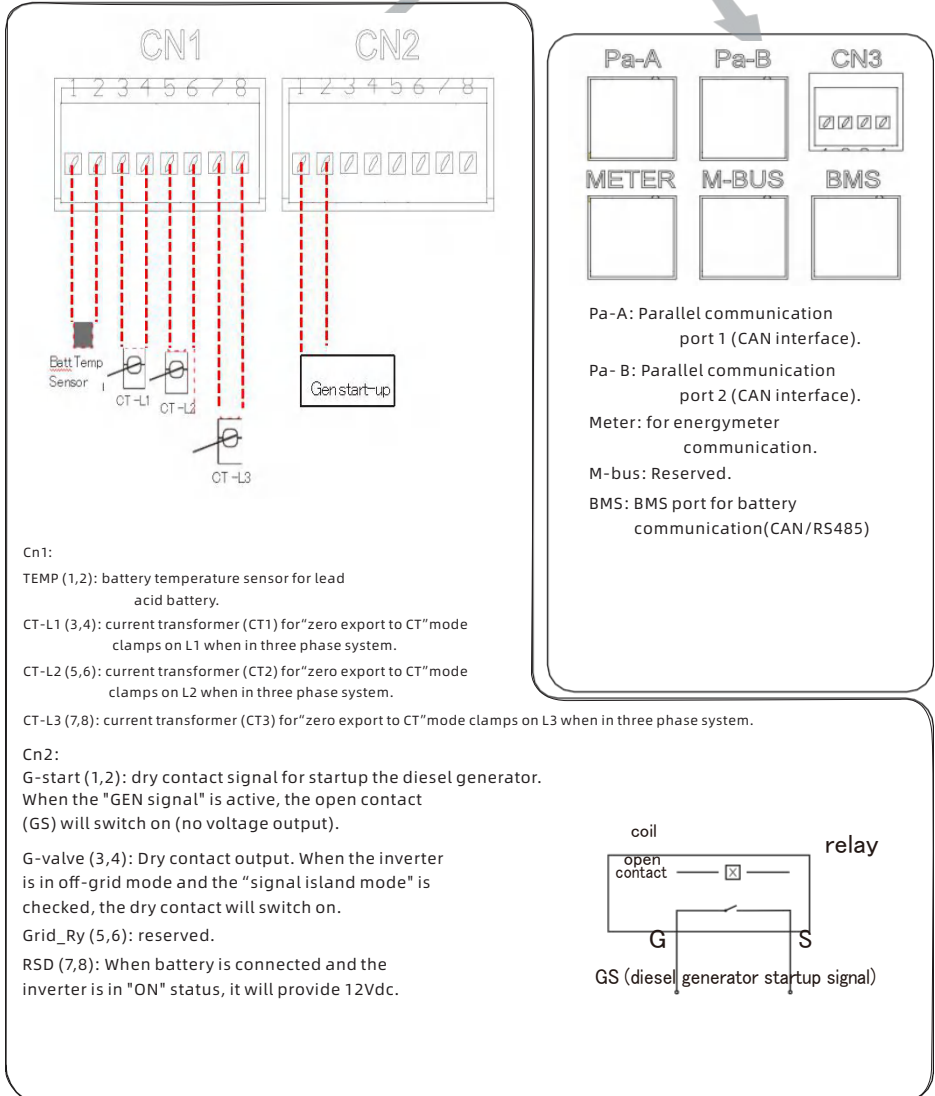

3.3.3 Temperature sensor connection for lead-acid battery

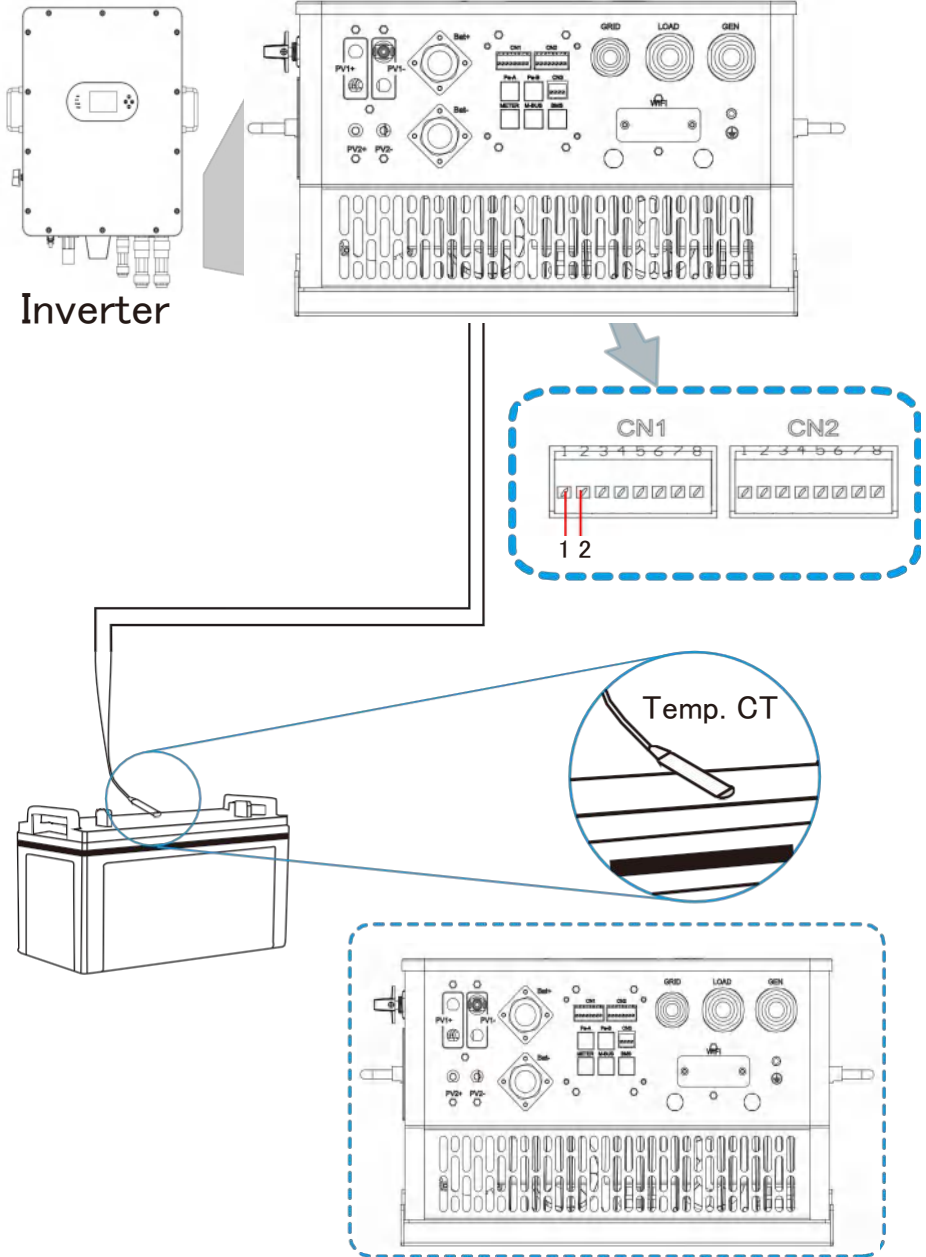

4.4 Grid connection and backup load connection

· Before connecting to the grid, a separate AC breaker must be installed between the inverter and the grid, and also between the backup load and the inverter. This will ensure the inverter can be securely disconnected during maintenance and fully protected from over current. Therecommended of AC breaker for the load port is 63A for 8kW, 63A for 10kW and 63A for 12kW. The recommended of AC breaker for the grid port is 63A for 8kW, 63A for 10kW and 63A for 12kW.

· There are three terminal blocks with "Grid" "Load" and "GEN" markings. Please do not mis connect input and output connectors.



All wiring must be performed by a qualified personnel. It is very important for system safety and efficient operation to use appropriate cable for AC input connection. To reduce risk of injury, please use the proper recommended cable as below.

backup load connection

Model	Wire Size	Cable(mm ²)	Torque value(max)
6kW	8AWG	8	1.2Nm

Grid connection

Model	Wire Size	Cable(mm ²)	Torque value(max)
6kW	8AWG	8	1.2Nm

Chart 3-3 Recommended Size for AC wires

Please follow below steps to implement AC input/output connection:

1. No need to open the cover, there are GRID, LOAD, GEN interfaces preset on the outside of the chassis, just unscrew the outer plastic cover of the terminals and screw the copper lugs into the interfaces and then use screws to fix them, and then finally tighten the outer plastic cover, that is, the installation is complete!



Be sure that AC power source is disconnected before attempting to wire it to the unit.

1. Then, insert AC output wires according to polarities indicated on the terminal block and tighten terminal. Be sure to connect corresponding N wires and PE wires to related terminals as well.

2. Make sure the wires are securely connected.

2. Appliances such as air conditioner are required at least 2-3 minutes to restart because it is required to have enough time to balance refrigerant gas inside of circuit. If a power shortage occurs and recovers in short time, it will cause damage to your connected appliances. To prevent this kind of damage, please check manufacturer of air conditioner if it is equipped with time-delay function before installation. Otherwise, this inverter will trigger overload fault and cut off output to protect your appliance but sometimes it still causes internal damage to the air conditioner

4.5 PV Connection

Before connecting to PV modules, please install a separately DC circuit breaker between inverter and PV modules. It is very important for system safety and efficient operation to use appropriate cable for PV module connection. To reduce risk of injury, please use the proper recommended cable size as below.

Model	Wire Size	Cable(mm ²)
6/8/10/12kW	12AWG	4

Chart 3-4 Cable size



To avoid any malfunction, do not connect any PV modules with possible current leakage to the inverter. For example, grounded PV modules will cause current leakage to the inverter. When using PV modules, please ensure the PV+ & PV- of solar panel is not connected to the system ground bar.



It is requested to use PV junction box with surge protection. Otherwise, it will cause damage on inverter when lightning occurs on PV modules.

4.5.1 PV Module Selection:

When selecting proper PV modules, please be sure to consider below parameters:

- 1) Open circuit Voltage (Voc) of PV modules not exceeds max. PV array open circuit voltage of inverter.
- 2) Open circuit Voltage (Voc) of PV modules should be higher than min. start voltage.
- 3) The PV modules used to connected to this inverter shall be Class A rating certified according to IEC 61730.

Inverter Model	5kW	6kW	8kW	10kW	12kW
PV Input Voltage	550V (160V~800V)				
PV Array MPPT Voltage Range	200V-650V				
No. of MPP Trackers	2				
6/8/10/12kW	1+1	1+1	1+1	2+1	2+1

4.5.2 PV Module Wire Connection:

1. Switch the Grid Supply Main Switch(AC)OFF.
2. Switch the DC Isolator OFF.
3. Assemble PV input connector to the inverter.



Safety Hint:

When using PV modules, please ensure the PV+ & PV- of solar panel is not connected to the system ground bar.



Safety Hint:

Before connection, please make sure the polarity of the output voltage of PV array matches the "DC+" and "DC-" symbols.



Safety Hint:

Before connecting inverter, please make sure the PV array open circuit voltage is within the 800V of the inverter.



Pic 5.1 DC+ male connector



Pic 5.2 DC- female connector



Safety Hint:

When using PV modules, please ensure the PV+ & PV- of solar panel is not connected to the system ground bar.

Cable type	Crossection (mm ²)	
	Range	Recommended value
Industry generic PV cable (model: PV1-F)	4.0~6.0 (12~10AWG)	4.0(12AWG)

Chart 3-6

The steps to assemble the DC connectors are listed as follows:

a) Strip off the DC wire about 7mm, disassemble the connector cap nut (see picture 5.3).

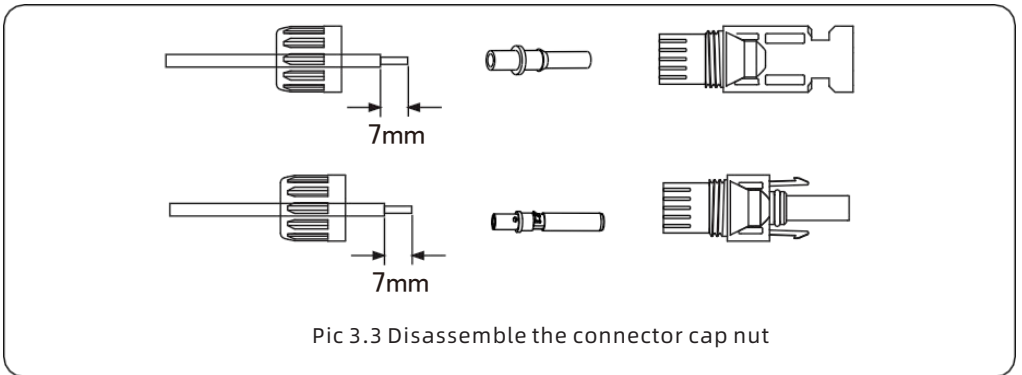

b) Crimping metal terminals with crimping pliers as shown in picture 5.4.

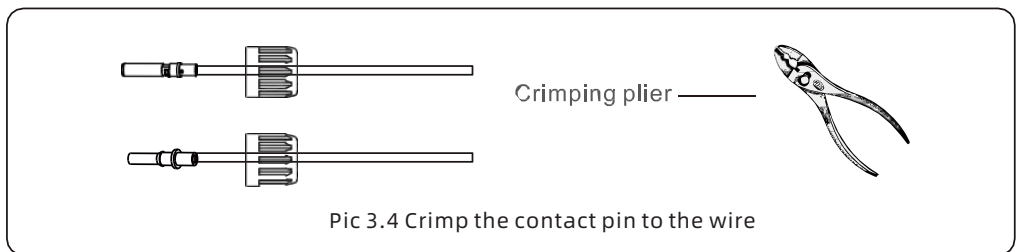

c) Insert the contact pin to the top part of the connector and screw up the cap nut to the top part of the connector. (as shown in picture 5.5)

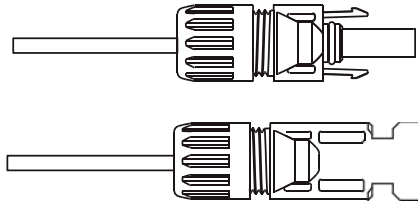

Pic 3.5 connector with cap nut screwed on

d) Finally insert the DC connector into the positive and negative input of the inverter, shown as picture 5.6

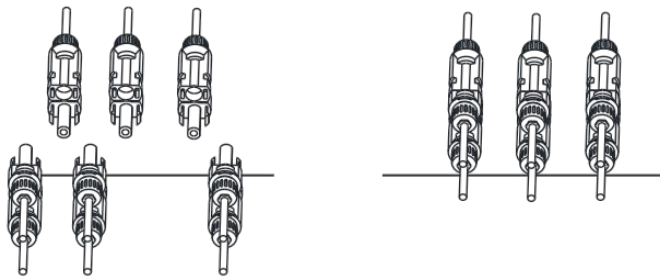

Pic 3.6 DC input connection



Warning:

Sunlight shines on the panel will generate voltage, high voltage in series may cause danger to life. Therefore, before connecting the DC input line, the solar panel needs to be blocked by the opaque material and the DC switch should be 'OFF', otherwise, the high voltage of the inverter may lead to life-threatening conditions.



Warning:

Please use its own DC power connector from the inverter accessories. Do not interconnect the connectors of different manufacturers. Max. DC input current should be 20A. if exceeds, it may damage the inverter and it is not covered by warranty.

4.6 CT Connection

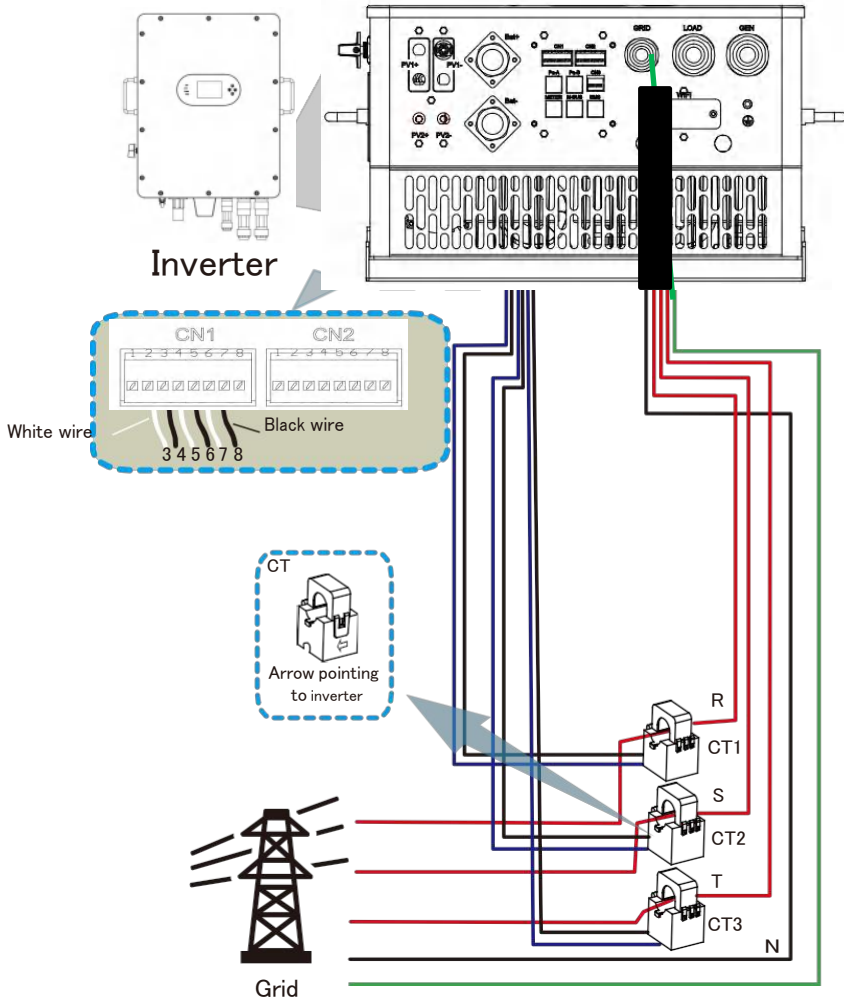

***Note:** when the reading of the load power on the LCD is not correct, please reverse the CT arrow.

4.6.1 Meter Connection

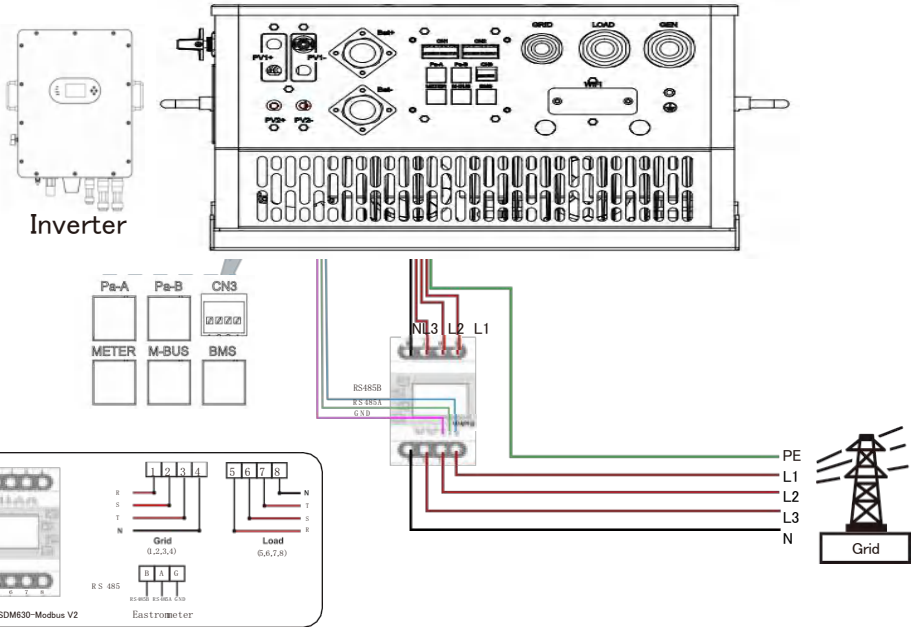
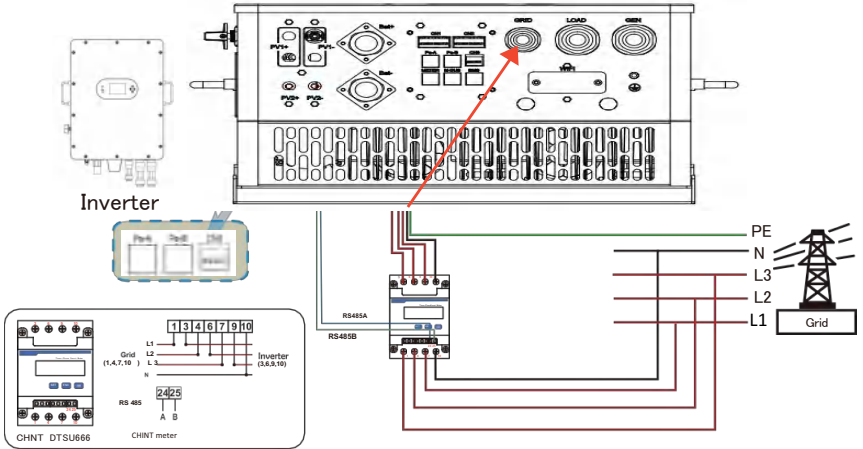



Note:

When the inverter is in the off-grid state, the N line needs to be connected to the earth.



Note:

When the inverter is in the off-grid state, the N line needs to be connected to the earth.

4.7 Earth Connection(mandatory)

Ground cable shall be connected to ground plate on grid side this prevents electric shock if the original protective conductor fails.

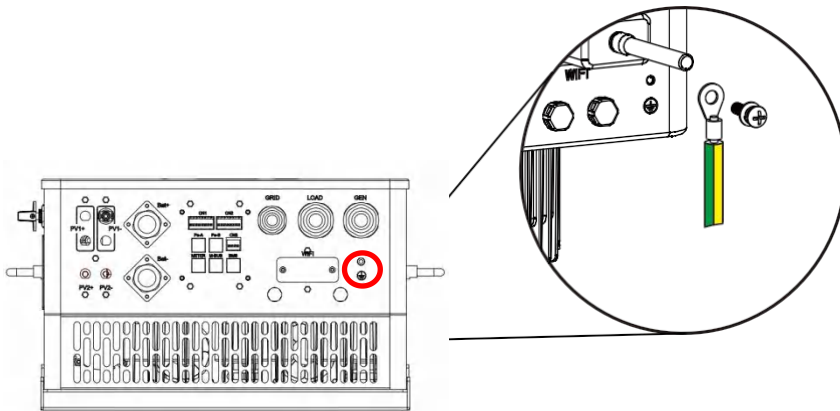

4.8 WIFI Connection

For the configuration of Wi-Fi Plug, please refer to illustrations of the Wi-Fi Plug. The Wi-Fi Plug is not a standard configuration, it's optional.

3.9 Wiring System for Inverter

This diagram is an example for an application that neutral connects with the PE in a distribution box.

For countries such as Australia, New Zealand, South Africa, etc., please follow local wiring regulations!

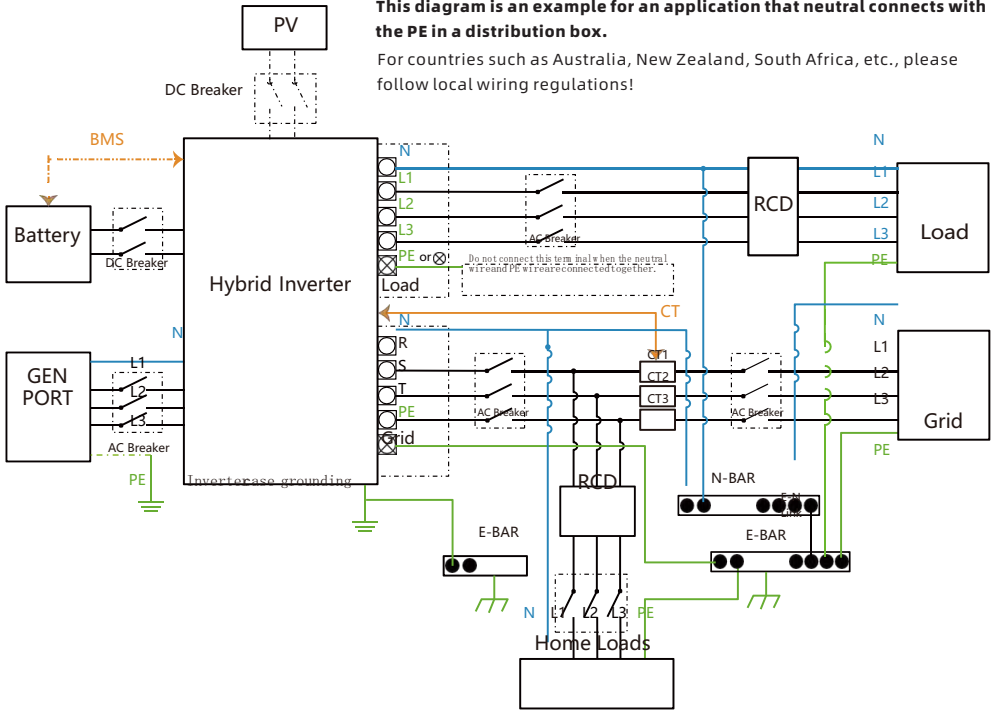

3.10 Wiring diagram

This diagram is an example for an application in which neutral is separated from the PE in the distribution box.

For countries such as China, Germany, the Czech Republic, Italy, etc., please follow local wiring regulations!

Note: Backup function is optional in German market. please leave backup side empty if backup function is not available in the inverter.

When the inverter is working in backup mode, neutral and PE on the backup side are connected via the internal relay. Also, this internal relay will be open when the inverter is working in grid tied mode.

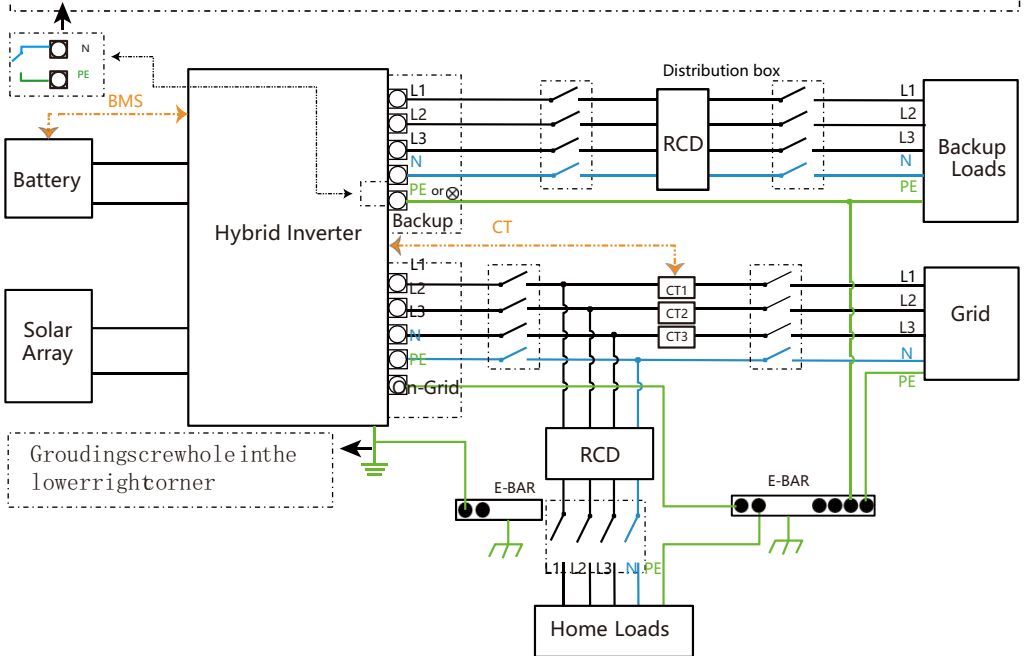

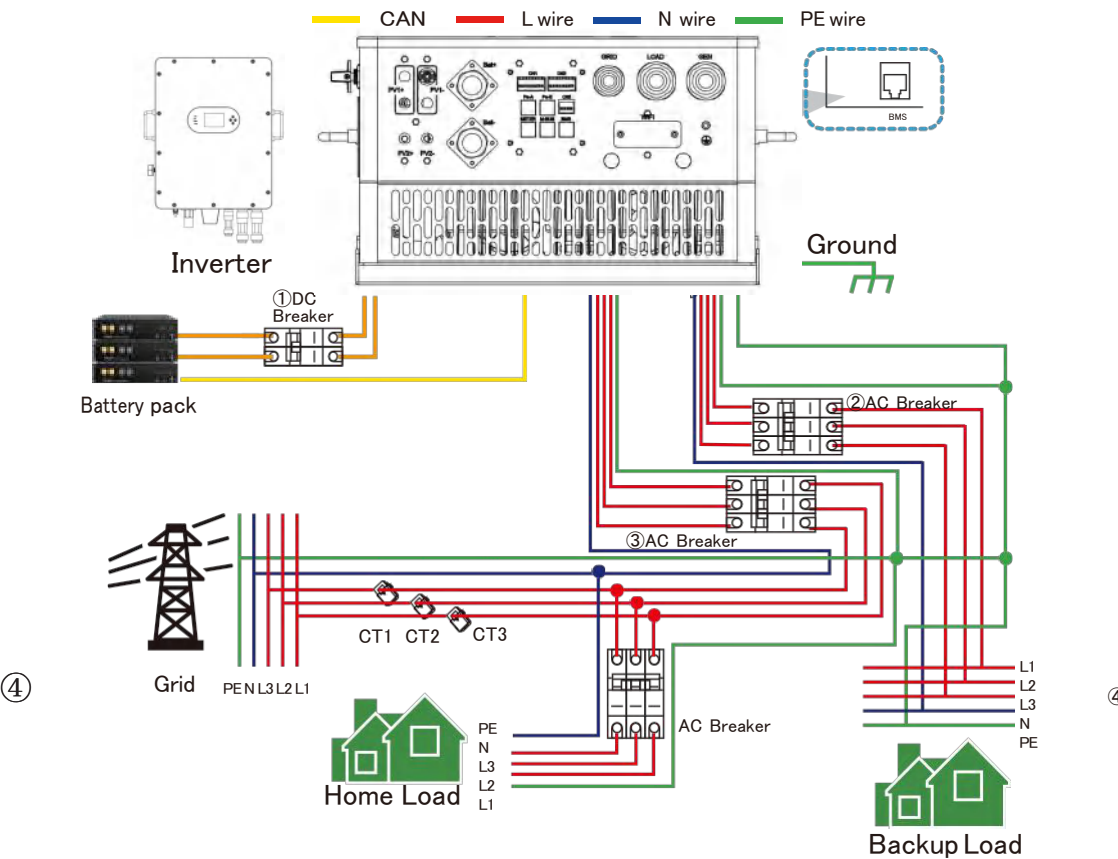

① DC Breaker for battery

PD0060G-TPM-EU
 PD0080G-TPM-EU
 PD0100G-TPM-EU
 PD0120G-TPM-EU

② AC Breaker for backup load

PD0060G-TPM-EU
 PD0080G-TPM-EU
 PD0100G-TPM-EU
 PD0120G-TPM-EU

③ AC Breaker for grid

PD0060G-TPM-EU
 PD0080G-TPM-EU
 PD0100G-TPM-EU
 PD0120G-TPM-EU

④ AC Breaker for home load

Depends on household loads

3.11 Typical application diagram of diesel generator

— CAN — L wire — N wire — PE wire

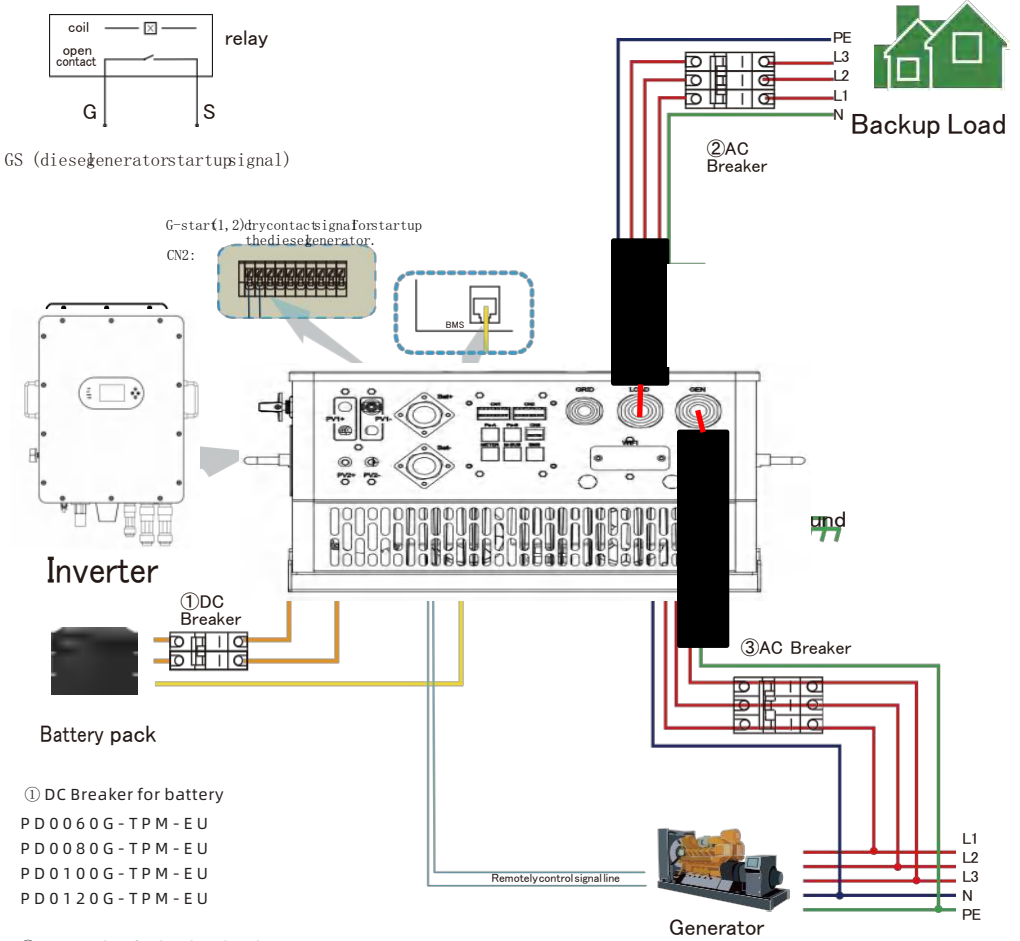

① DC Breaker for battery

PD0060G-TPM-EU
 PD0080G-TPM-EU
 PD0100G-TPM-EU
 PD0120G-TPM-EU

② AC Breaker for backup load

SUNPD0060G-TPM-EU
 PD0080G-TPM-EU
 PD0100G-TPM-EU
 PD0120G-TPM-EU

③ AC Breaker for Generator port

PD0060G-TPM-EU
 PD0080G-TPM-EU
 PD0100G-TPM-EU
 PD0120G-TPM-EU

3.12 Three phase parallel connection diagram

Max. 10pcs parallel for on-grid and off-grid operation.

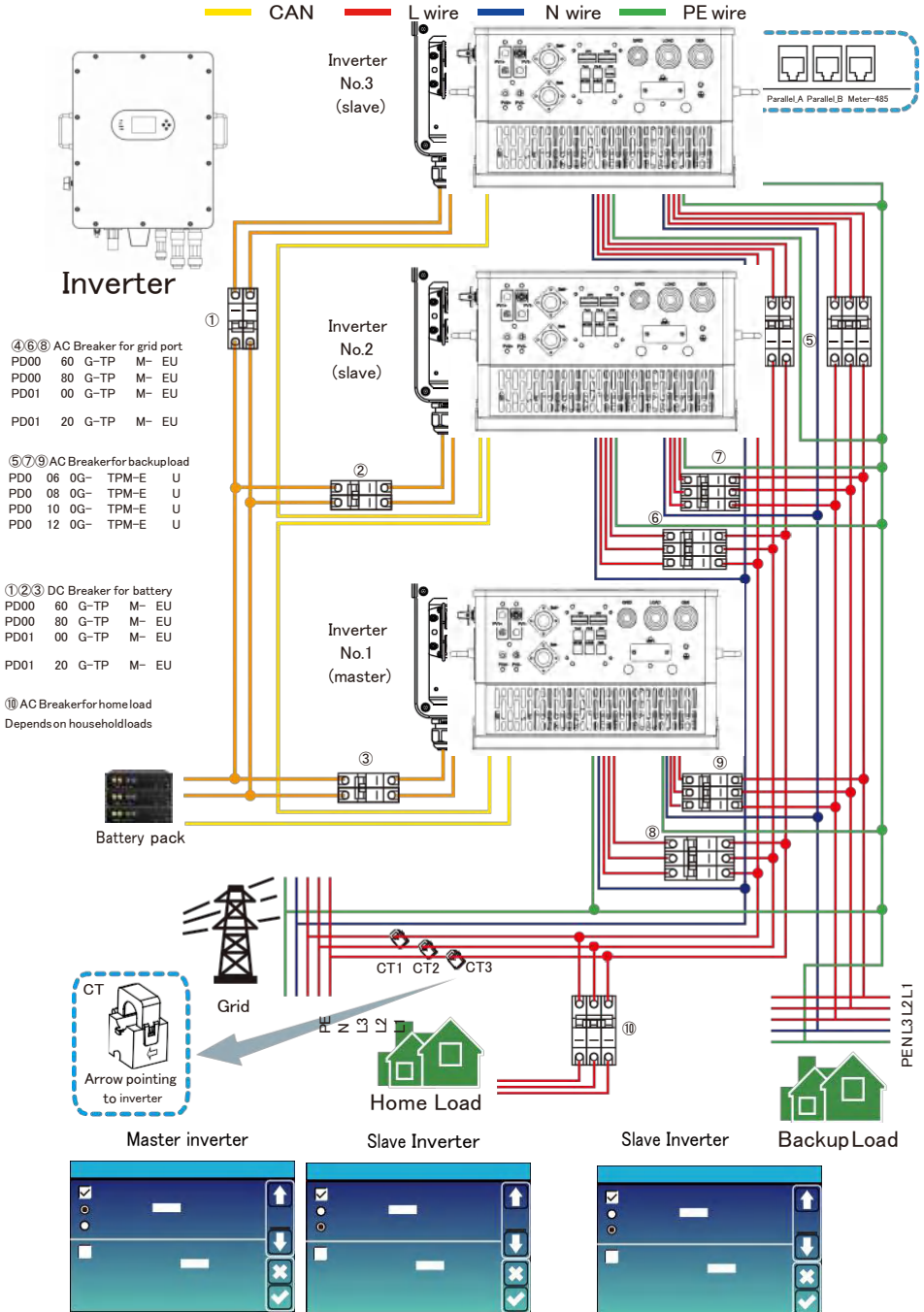

4. OPERATION

4.1 Power ON/OFF

Once the unit has been properly installed and the batteries are connected well, simply press On/Off button (located on the left side of the case) to turn on the unit. When system without battery connected, but connect with either PV or grid, and ON/OFF button is switched off, LCD will still light up (Display will show OFF), In this condition, when switch on ON/OFF button and select NO battery, system can still working.

4.2 Operation and Display Panel

The operation and display panel, shown in below chart, is on the front panel of the inverter. It includes four indicators, four function keys and a LCD display, indicating the operating status and input/output power information.

LED Indicator		Messages
DC	Green led solid light	PV Connection normal
AC	Green led solid light	Grid Connection normal
Normal	Green led solid light	Inverter operating normal
Alarm	Red led solid light	Malfunction or warning

Chart 4-1 LED indicators

Function Key	Description
Esc	To exit setting mode
Up	To go to previous selection
Down	To go to next selection
Enter	To confirm the selection

Chart 4-2 Function Buttons

5. LCD Display Icons

5.1 Main Screen

The LCD is touchscreen, below screen shows the overall information of the inverter.

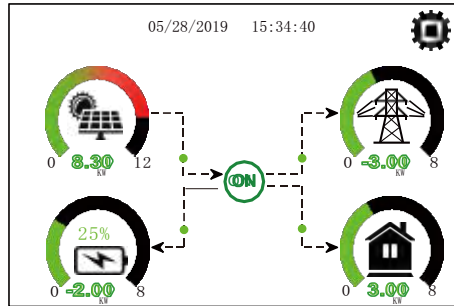

1. The icon in the center of the home screen indicates that the system is Normal operation. If it turns into "comm./F01~F64", it means the inverter has communication errors or other errors, the error message will display under this icon(F01-F64 errors, detail error info can be viewed in the System Alarms menu).

2. At the top of the screen is the time.

3. System Setup Icon, Press this set button, you can enter into the system setup screen which includes Basic Setup, Battery Setup, Grid Setup, System Work Mode, Generator port use, Advanced function and Li-Batt info.

4. The main screen showing the info including Solar, Grid, Load and Battery. It also displays the energy flow direction by arrow. When the power is approximate to high level, the color on the panels will change from green to red so system info showing vividly on the main screen.

- PV power and Load power always keep positive.
- Grid power negative means sell to grid, positive means get from grid.
- Battery power negative means charge, positive means discharge.

5.1.1 LCD operation flow chart

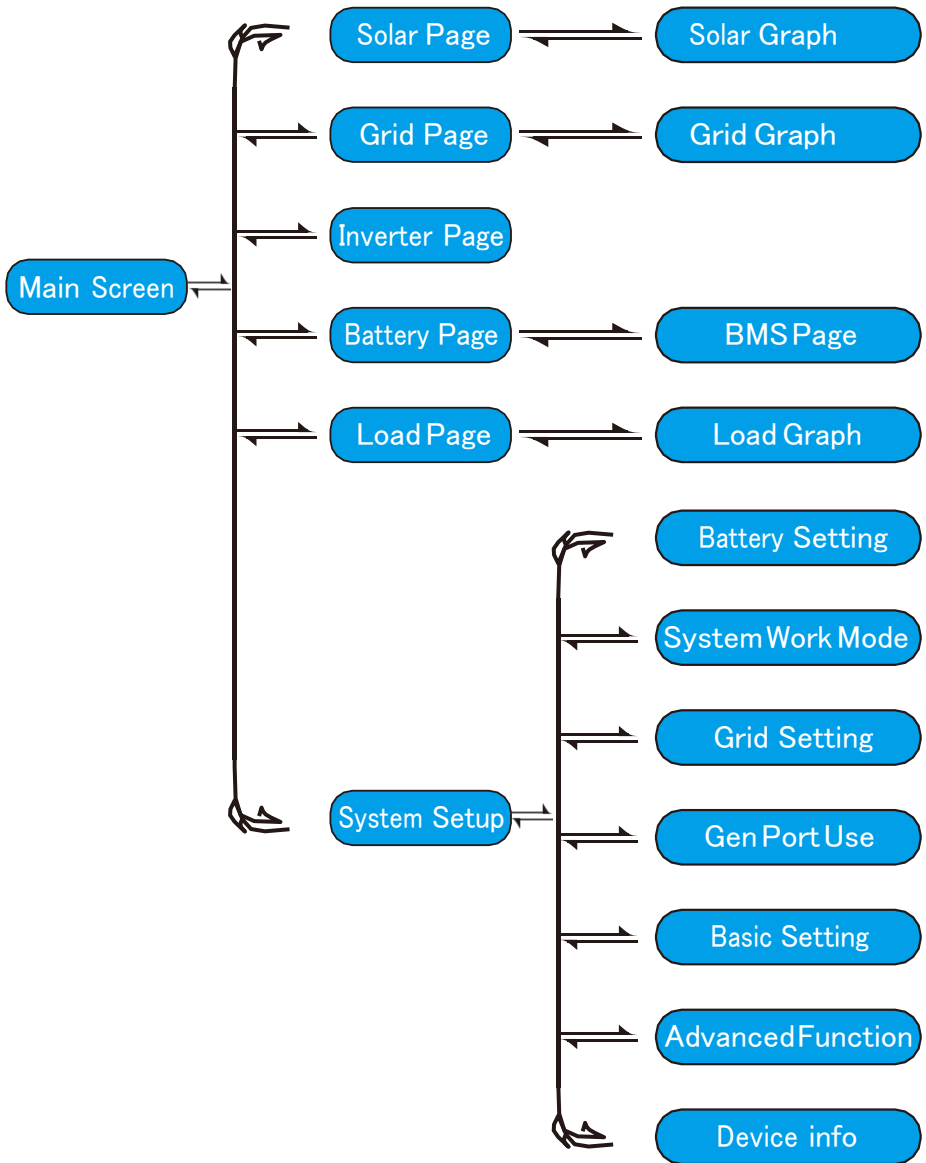

5.2 Solar Power Curve

Solar

Power: 1560W	①	Today=8.0 KWH	③
PV1-V: 286V	PV2-V: 45V	Total=12.00 KWH	
PV1-I: 5.5A	PV2-I: 0.0A		
PV1-P: 1559W	PV2-P: 1W		

②

Energy

This is Solar Panel detail page.

- ① Solar Panel Generation.
- ② Voltage, Current, Power for each MPPT.
- ③ Solar Panel energy for Day and Total.

Press the "Energy" button will enter into the power curve page

1166w	1244w 50Hz	-81w 50Hz	①
221v 0w	222v 0.8w	222v 0.1A	
229v 1166w	229v 5.0w	230v 0.1A	
225v 0w	229v 0.9w	223v 0.1A	
	HM: LD:	INV_P:	
	-10W 28W	-30W	
Load	5W 1192W	-26W AC_T:	
SOC:99%	0W 24W	-25W 38.8C	
-21w	Grid	Inverter	
BAT_V: 53.65V	DC_P1: 0W	DC_P2: 0W	
BAT_I: -0.41A	DC_V1: 0V	DC_V2: 0V	
BAT_T: 27.0C	DC_I1: 0.0A	DC_I2: 0.0A	
Battery	PV1	PV2	

This is Solar Panel detail page.

- ① Inverter Generation.
- ② Voltage, Current, Power for each Phase. AC-T: mean Heat-sink temperature.

Load

Power: 55W	①	Today=0.5 KWH	③
		Total=1.60 KWH	
L1: 220V	P1: 19W	②	
L2: 220V	P2: 18W		
L3: 220V	P3: 18W		

Energy

This is Back-up Load detail page.

- ① Back-up Power.
- ② Voltage, Power for each Phase.
- ③ Back-up consumption for Day and Total.

Press the "Energy" button will enter into the power curve page.

Grid

Stand by	①	BUY	③
0W		Today=2.2KWH	
0.0Hz		Total=11.60 KWH	
CT1: 0W	LD1: 0W	SELL	
CT2: 0W	LD2: 0W	②	
CT3: 0W	LD3: 0W	Today=0.0KWH	
		Total=8.60 KWH	
L1: 0V	L2: 0V	L3: 0V	

Energy

This is Back-up Load detail page.

- ① Status, Power, Frequency
 - ② L: Voltage for each Phase
 - CT: Power detected by the external current sensors
 - LD: Power detected using internal sensors on AC grid in/out breaker
 - ③ BUY: Energy from Grid to Inverter, SELL: Energy from Inverter to grid.
- Press the "Energy" button will enter into the power curve page.

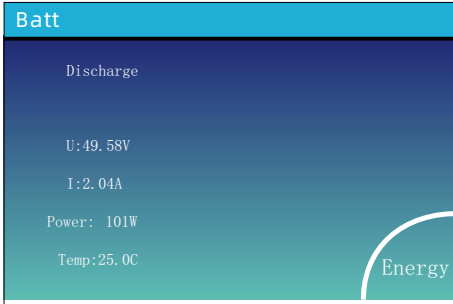

This is Battery detail page.

if you use Lithium Battery, you can enter BMS page.

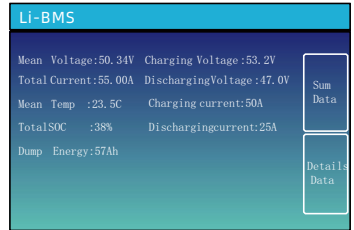

	Vol	Cur	Tem p	SOC	Energy	Charge	Fault
1	50.38V	19.70A	30.6C	52.0%	26.0Ah	0.0V	0.0A
2	50.33V	19.10A	31.0C	51.0%	25.5Ah	53.2V	25.0A
3	50.30V	14.90A	20.2C	12.0%	4.0Ah	53.2V	25.0A
4	0.00V	0.00A	0.0C	0.0%	0.0Ah	0.0V	0.0A
5	0.00V	0.00A	0.0C	0.0%	0.0Ah	0.0V	0.0A
6	0.00V	0.00A	0.0C	0.0%	0.0Ah	0.0V	0.0A
7	0.00V	0.00A	0.0C	0.0%	0.0Ah	0.0V	0.0A
8	0.00V	0.00A	0.0C	0.0%	0.0Ah	0.0V	0.0A
9	0.00V	0.00A	0.0C	0.0%	0.0Ah	0.0V	0.0A
10	0.00V	0.00A	0.0C	0.0%	0.0Ah	0.0V	0.0A
11	0.00V	0.00A	0.0C	0.0%	0.0Ah	0.0V	0.0A
12	0.00V	0.00A	0.0C	0.0%	0.0Ah	0.0V	0.0A
13	0.00V	0.00A	0.0C	0.0%	0.0Ah	0.0V	0.0A
14	0.00V	0.00A	0.0C	0.0%	0.0Ah	0.0V	0.0A
15	0.00V	0.00A	0.0C	0.0%	0.0Ah	0.0V	0.0A

5.3 Curve Page-Solar & Load & Grid

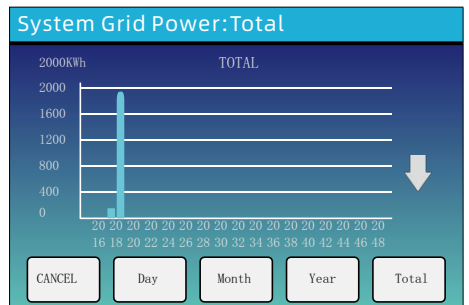
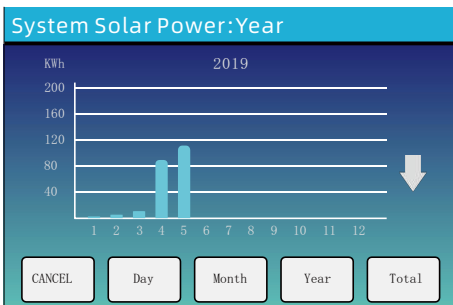
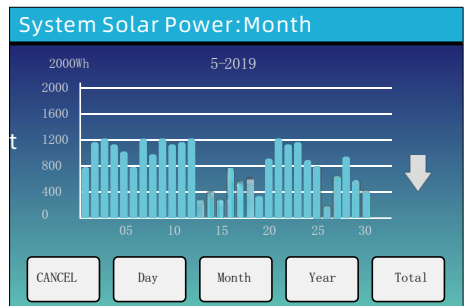
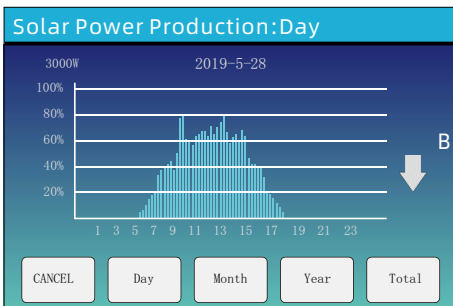

Solar power curve for daily, monthly, yearly and total can be roughly checked on the LCD, for more accuracy power generation, pls check on the monitoring system. Click the up and down arrow to check power curve of different period.

5.4 System Setup Menu

	<p>This is the System Setup page</p>
--	--------------------------------------

5.5 Basic Setup Menu

	<p>Factory Reset: Reset all parameters of the inverter.</p> <p>Lock out all changes: Enable this menu for setting parameters that require locking and cannot be set up. Before performing a successful factory reset and locking the systems, to keep all changes you need to type in a password to enable the setting.</p> <p>The password for factory settings is 9999 and for lock out is 7777.</p>
--	--

	<p>Factory Reset Password: 9999</p> <p>Lock out all changes Password: 7777</p>
--	--

5.6 Battery Setup Menu

Battery capacity: it tells hybrid inverter to know your battery bank size.

Use Batt V: Use Battery Voltage for all the settings(V).

Use Batt %: Use Battery SOC for all the settings(%).

Max.A charge/discharge: Max battery charge/discharge current(0-120A for 5kW model, 0-150A for 6kW model, 0-190A for 8kW model, 0-210A for 10kW model,0-240A for 12kW model).

For AGM and Flooded, we recommend Ah battery size x 20%= Charge/Discharge amps.
 .For Lithium, we recommend Ah battery size x 50% = Charge/Discharge amps.
 .For Gel, follow manufacturer's instructions.

No Batt: tick this item if no battery is connected to the system.

Active battery: This feature will help recover a battery that is over discharged by slowly charging from the solar array or grid.

This is Battery Setup page. ①③

Start =30%: Percent S.O.C at 30% system will AutoStart a connected generator to charge the battery bank.

A = 40A: Charge rate of 40A from the attached generator in Amps.

Gen Charge: uses the gen input of the system to charge battery bank from an attached generator.

Gen Signal: Normally open relay that closes when the Gen Start signal state is active.

Gen Max Run Time: It indicates the longest time Generator can run in one day, when time is up, the Generator will be turned off. 24H meansthat it does not shut down all the time.

Gen Down Time: It indicates the delay time of the Generator to shut down after it hasreached the running time.

This is Grid Charge, you need select. ②

Start =30%: No use, Just for customization.

A = 40A: It indicates the Current that the Grid charges the Battery.

Grid Charge: It indicates that the grid charges the battery.

Grid Signal: Disable.

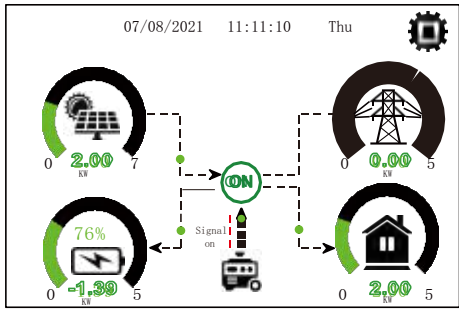

This page tells the PV and diesel generator power the load and battery.

Generator

Power: 6000W Today=10 KWH
 Total =10 KWH

V_L1: 230V P_L1: 2KW
 V_L2: 230V P_L2: 2KW
 V_L3: 230V P_L3: 2KW

This page tells generator output voltage, frequency, power. And, how much energy is used from generator.

Battery Setting

LithiumMode

Shutdown

Low Batt

Restart

↑
Batt Set3
↓
✕
✓

Lithium Mode: This is BMS protocol. Please reference the document (Approved Battery).

Shutdown 10%: It indicates the inverter will shutdown if the SOC below this value.

Low Batt 20%: It indicates the inverter will alarm if the SOC below this value.

Restart 40%: Battery voltage at 40% AC output will resume.

Battery Setting

FloatV ①

AbsorptionV

EqualizationV

EqualizationDays

EqualizationHours

Shutdown ③

Low Batt

Restart

TEMPCO (mV/C/Ce11) ②

BattResistance

↑
Batt Set3
↓
✕
✓

There are 3 stages of charging the Battery . ①

This is for professional installers, you can keep it if you do not know. ②

Shutdown 20%: The inverter will shutdown if the SOC below this value.

Low Batt 35%: The inverter will alarm if the SOC below this value. ③

Restart 50%: Battery SOC at 50% AC output will resume.

Recommended battery settings

Battery Type	Absorption Stage	Float Stage	Torque value (every 30 days 3hr)
AGM (or PCC)	14.2V (57.6V)	13.4V (53.6V)	14.2V(57.6V)
Ge	14.1V (56.4V)	13.5V (54.0V)	
Wet	14.7V (59.0V)	13.7V (55.0V)	14.7V(59.0V)
Lithium	Follow its BMS voltage parameters		

5.7 System Work Mode Setup Menu

System Work Mode

SellingFirst 12000 Max SolarPower

Zero Export To Load SolarSell

Zero Export To CT SolarSell

Max SellPower: 12000 Zero-exportPower: 20

Energy pattern BattFirst LoadFirst

GridPeak Shaving 8000 Power

↑

Work Model

↓

✕

✓

Work Mode

Selling First: This Mode allows hybrid inverter to sell back any excess power produced by the solar panels to the grid. If time of use is active, the battery energy also can be sold into grid.

The PV energy will be used to power the load and charge the battery and then excess energy will flow to grid. Power source priority for the load is as follows:

1. Solar Panels.
2. Grid.
3. Batteries (until programmable % discharge is reached).

Zero Export To Load: Hybrid inverter will only provide power to the backup load connected. The hybrid inverter will neither provide power to the home load nor sell power to grid. The built-in CT will detect power flowing back to the grid and will reduce the power of the inverter only to supply the local load and charge the battery.

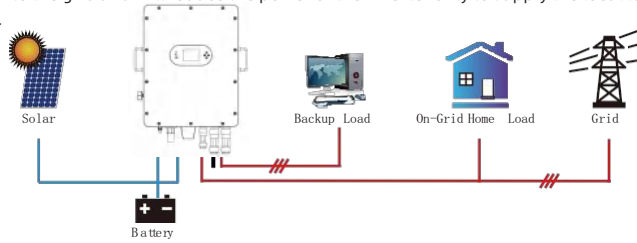

Zero Export To Load: Hybrid inverter will only provide power to the backup load connected. The hybrid inverter will neither provide power to the home load nor sell power to grid. The built-in CT will detect power flowing back to the grid and will reduce the power of the inverter only to supply the local load and charge the battery.

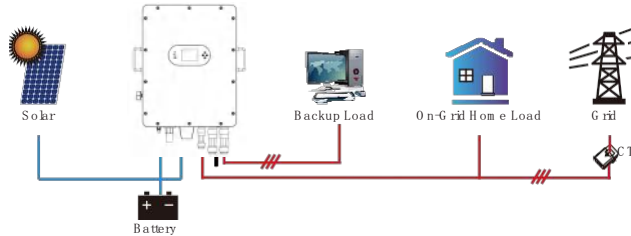

Solar Sell: "Solar sell" is for Zero export to load or Zero export to CT: when this item is active, the surplus energy can be sold back to grid. When it is active, PV Power source priority usage is as follows: load consumption and charge battery and feed into grid.

Max. sell power: Allowed the maximum output power to flow to grid

Zero-export Power: for zero-export mode, it tells the grid output power. Recommend to set it as 20-100W to ensure the hybrid inverter won't feed power to grid.

Energy Pattern: PV Power source priority.

Batt First: PV power is firstly used to charge the battery and then used to power the load. If PV power is insufficient, grid will make supplement for battery and load simultaneously.

Load First: PV power is firstly used to power the load and then used to charge the battery. If PV power is insufficient, Grid will provide power to load.

Max Solar Power: allowed the maximum DC input power.

Grid Peak-shaving: when it is active, grid output power will be limited within the set value. If the load power exceeds the allowed value, it will take PV energy and battery as supplement. If still can't meet the load requirement, grid power will increase to meet the load needs.

System Work Mode

Grid Charge	Gen	Time	Power	Batt	
<input type="checkbox"/>	<input type="checkbox"/>	01:00	5:00	12000	49.0V
<input type="checkbox"/>	<input type="checkbox"/>	05:00	9:00	12000	50.2V
<input checked="" type="checkbox"/>	<input type="checkbox"/>	09:00	13:00	12000	50.9V
<input checked="" type="checkbox"/>	<input type="checkbox"/>	13:00	17:00	12000	51.4V
<input checked="" type="checkbox"/>	<input type="checkbox"/>	17:00	21:00	12000	47.1V
<input checked="" type="checkbox"/>	<input type="checkbox"/>	21:00	01:00	12000	49.0V

Time Of Use
 Grid Charge
 Gen

Time of use: it is used to program when to use grid or generator to charge the battery, and when to discharge the battery to power the load. Only tick "Time Of Use" then the follow items (Grid, charge, time, power etc.) will take effect.

Note: when in selling first mode and click time of use, the battery power can be sold into grid.

Grid charge: utilize grid to charge the battery in a time period.

Gen charge: utilize diesel generator to charge the battery in a time period.

Time: real time, range of 01:00-24:00.

Note: when the grid is present, only the "time of use" is ticked, then the battery will discharge. Otherwise, the battery won't discharge even the battery SOC is full. But in the off-grid mode (when grid is not available, inverter will work in the off-grid mode automatically).

Power: Max. discharge power of battery allowed.

Batt(V or SOC %): battery SOC % or voltage at when the action is to happen.

For example

During 01:00-05:00,

if battery SOC is lower than 80%, it will use grid to charge the battery until battery SOC reaches 80%.

During 05:00-08:00,

if battery SOC is higher than 40%, hybrid inverter will discharge the battery until the SOC reaches 40%. At the same time, if battery SOC is lower than 40%, then grid will charge the battery SOC to 40%.

During 08:00-10:00,,

if battery SOC is higher than 40%, hybrid inverter will discharge Batt Work Mode2 the battery until the SOC reaches 40%.

During 10:00-15:00,

when battery SOC is higher than 80%, hybrid inverter will discharge the battery until the SOC reaches 80%.

During 15:00-18:00,

when battery SOC is higher than 40%, hybrid inverter will discharge the battery until the SOC reaches 40%.

During 18:00-01:00,

when battery SOC is higher than 35%, hybrid inverter will discharge the battery until the SOC reaches 35%.

Battery Setting

Start

A

Gen Charge Grid Charge ③

Gen Signal GridSignal

Gen Max Run Time

Gen Down Time

System Work Mode

② Grid Charge Gen

Time Of Use

Time	Power	Batt	
01:00	5:00	12000	80%
05:00	8:00	12000	40%
08:00	10:00	12000	40%
10:00	15:00	12000	80%
15:00	18:00	12000	40%
18:00	01:00	12000	35%

It allows users to choose which day to execute the setting of "Time of Use". For example, the inverter will execute the time of use page on Mon/Tue/Wed/Thu/Fri/Sat only.

System Work Mode

Mon Tue Wed Thu Fri Sat Sun

5.8 Grid Setup Menu

Grid Setting/Grid code selection

GridMode General Standard 0/11

GridFrequency 50HZ Phase Type 0/120/240
 60HZ 0/240/120

GridLevel LN:220VAC LL:380VAC

IT system-neutral is not grounded

Grid Set1
⌵
✕
✓

Grid Mode: General Standard、UL1741 & IEEE1547、CPUC RULE21、SRD-UL-1741、CEI 0-21、Australia A、Australia B、Australia C、EN50549_CZ-PPDS(>16A)、New Zealand、VDE4105、OVE-Directive R25. Please follow the local grid code and then choose the corresponding grid standard.

Grid level: there're several voltage levels for the inverter output voltage when it is in off-grid mode.

LN:230VAC LL:400VAC, LN:240VAC LL:420VAC,
LN:120VAC LL:208VAC, LN:133VAC LL:230VAC.

IT system: If the grid system is IT system, then please

enable this option. For example, the IT grid system voltage is 230Vac (the Line voltage between any two live lines in a three-phase circuit is 230Vac, and the diagram is as follow) then please enable "IT system" and tick the "Grid level" as LN:133VAC LL:230VAC as below picture shows.

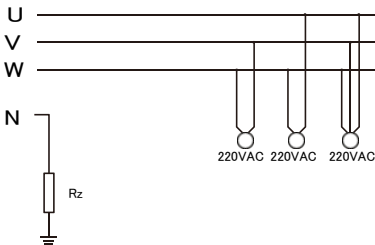

Rz: Large resistance ground resistor. Or the system doesn't have Neutral line

Grid Setting/Grid code selection

GridMode General Standard 0/11

GridFrequency 50HZ Phase Type 0/120/240
 60HZ 0/240/120

GridLevel LN:133VAC LL:230VAC

IT system-neutral is not grounded

Grid Set1
⌵
✕
✓

Grid Setting/Connect

Normal connect	Nom a Ramp rate	10s
Low frequency 48.00Hz	High frequency	51.50Hz
Low voltage 185.0V	High voltage	265.0V
Reconnect after trip	Reconnect Ramp rate	36s
Low frequency 48.20Hz	High frequency	51.30Hz
Low voltage 187.0V	High voltage	263.0V
Reconnection Time	PF	1.000

Grid Set2
⌵
✕
✓

Normal connect: The allowed grid voltage/frequency range when the inverter first time connect to the grid.

Normal Ramp rate: It is the startup power ramp.

Reconnect after trip: The allowed grid voltage /frequency range for the inverter connects the grid after the inverter trip from the grid.

Reconnect Ramp rate: It is the reconnection power ramp.

Reconnection time: The waiting time period for the inverter connects the grid again.

PF: Power factor which is used to adjust inverter reactive power.

Grid Setting/IP Protection

Over voltage (10 min. running mean) 260.0V

HV3	265.0V	HF3	51.50Hz
HV2	265.0V 0.10s	HF2	51.50Hz 0.10s
HV1	265.0V 0.10s	HF1	51.50Hz 0.10s
LV1	185.0V 0.10s	LF1	48.00Hz 0.10s
LV2	185.0V 0.10s	LF2	48.00Hz 0.10s
LV3	185.0V	LF3	48.00Hz

Grid Set3
⌵
✕
✓

HV1: Level 1 overvoltage protection point;

HV2: Level 2 overvoltage protection point; ② 0.10s-Trip time.

HV3: Level 3 overvoltage protection point.

LV1: Level 1 undervoltage protection point;

LV2: Level 2 undervoltage protection point;

LV3: Level 3 undervoltage protection point.

HF1: Level 1 over frequency protection point;

HF2: Level 2 over frequency protection point;

HF3: Level 3 over frequency protection point.

LF1: Level 1 under frequency protection point;

LF2: Level 2 under frequency protection point;

LF3: Level 3 under frequency protection point.

Grid Setting/F(W)

F(W)

Over frequency	Droop F	40% PE/Hz
Start freq F	Stop freq F	51.5Hz
Start delay F	Stop delay F	0.00s

Under frequency	Droop F	40% PE/Hz
Start freq F	Stop freq F	49.80Hz
Start delay F	Stop delay F	0.00s

Grid Set4

FW: this series inverter is able to adjust inverter output power according to grid frequency.

Droop F: percentage of nominal power per Hz
For example, "Start freq F > 50.2Hz, Stop freq F < 51.5, Droop F=40%PE/Hz" when the grid frequency reaches 50.2Hz, the inverter will decrease its active power at Droop F of 40%. And then when grid system frequency is less than 50.1Hz, the inverter will stop decreasing output power.
For the detailed setup values, please follow the local grid code.

Grid Setting/V(W) V(Q)

V(W) V(Q)

V1	108.0%	P1	100%
V2	110.0%	P2	80%
V3	112.0%	P3	60%
V4	114.0%	P4	40%

Lock-in/Pn	5%	Lock-out/Pn	20%
V1	94.0%	Q1	44%
V2	97.0%	Q2	0%
V3	105.0%	Q3	0%
V4	108.0%	Q4	-44%

Grid Set5

V(W): It is used to adjust the inverter active power according to the set grid voltage.

V(Q): It is used to adjust the inverter reactive power according to the set grid voltage.
This function is used to adjust inverter output power (active power and reactive power) when grid voltage changes.

Lock-in/Pn 5%: When the inverter active power is less than 5% rated power, the VQ mode will not take effect.

Lock-out/Pn 20%: If the inverter active power is increasing from 5% to 20% rated power, the VQ mode will take effect again.

For example: V2=110%, P2=80%. When the grid voltage reaches the 110% times of rated grid voltage, inverter output power will reduce its active output power to 80% rated power.
For example: V1=94%, Q1=44%. When the grid voltage reaches the 94% times of rated grid voltage, inverter output power will output 44% reactive output power.
For the detailed setup values, please follow the local grid code.

Grid Setting/P(Q) P(PF)

P(Q) P(PF)

P1	0%	Q1	2%
P2	2%	Q2	0%
P3	0%	Q3	21%
P4	22%	Q4	25%

Lock-in/Pn	50%	Lock-out/Pn	50%
P1	0%	PF1	-0.000
P2	0%	PF2	-0.000
P3	0%	PF3	0.000
P4	62%	PF4	0.264

Grid Set6

P(Q): It is used to adjust the inverter reactive power according to the set active power.

P(PF): It is used to adjust the inverter PF according to the set active power.
For the detailed setup values, please follow the local grid code.

Lock-in/Pn 50%: When the inverter output active power is less than 50% rated power, it won't enter the P(PF) mode.

Lock-out/Pn 50%: When the inverter output active power is less than 50% rated power, it won't enter the P(PF) mode.

Note : only when the grid voltage is equal to or higher than 1.05times of rated grid voltage, then the P(PF) mode will take effect.

Grid Setting/LVRT

L/HVRT

HV3	0%	HV3_T	30.24s
HV2	0%	HV2_T	0.04s
HV1	0%	HV1_T	22.11s
LV1	0%	LV1_T	22.02s
LV2	0%	LV2_T	0.04s

Grid Set7

Reserved: This function is reserved. It is not recommended.

5.9 Generator Port Use Setup Menu

GEN PORT USE

Mode

Generator Input GEN connect to Grid input

Rated Power: 8000W

SmartLoad Output On Grid always on

AC Couple Frz High: 55.00Hz

Micro Inv Input

OFF(V): 51.0V

ON(V): 54.0V

MI export to Grid cutoff

PORT Set1

Generator input rated power: allowed Max. power from diesel generator.

GEN connect to grid input: connect the diesel generator to the grid input port.

Smart Load Output: This mode utilizes the Gen input connection as an output which only receives power when the battery SOC is above a user programmable threshold.

e.g. ON: 100%, OFF=95%: When the battery bank SOC reaches 100%, Smart Load Port will switch on automatically and power the load connected. When the battery bank SOC < 95% , the Smart Load Port will switch off automatically.

Smart Load OFF Batt

•Battery SOC at which the Smart load will switch off.

Smart Load ON Batt

•Battery SOC at which the Smart load will switch on. simultaneously and then the Smart load will switch on.

On Grid always on: When click "on Grid always on" the smart load will switch on when the grid is present.

Micro Inv Input: To use the Generator input port as a micro-inverter on grid inverter input (AC coupled), this feature will also work with "Grid-Tied" inverters.

***Micro Inv Input OFF:** when the battery SOC exceeds setting value, Microinverter or grid-tied inverter will shut down.

***Micro Inv Input ON:** when the battery SOC is lower than setting value, Microinverter or grid-tied inverter will start to work.

AC Couple Frz High: If choosing "Micro Inv input", as the battery SOC reaches gradually setting value (OFF), During the process, the microinverter output power will decrease linear. When the battery SOC equals to the setting value (OFF), the system frequency will become the setting value (AC couple Frz high) and the Microinverter will stop working. MI export to grid cutoff: Stop exporting power produced by the microinverter to the grid.

***Note:** Micro Inv Input OFF and On is valid for some certain FW version only.

5.10 Advanced Function Setup Menu

Advanced Function

Solar Arc Fault ON

Backup Delay: 0s

Clear Arc Fault

System selfcheck

Gen peak-shaving

DRM: 2000:1 C.T Ratio

Signal Island Mode

BMS Err Stop

Asymmetric phase feeding

CEI Report

Func Set1

Solar Arc Fault ON: This is only for US.

System self check: Disable. this is only for factory.

Gen Peak-shaving: Enable When the power of the generator exceeds the rated value of it, the inverter will provide the redundant part to ensure that the generator will not overload.

DRM: For AS4777 standard

Backup Delay: Reserved

BMS_Err_Stop: When it is active, if the battery BMS failed to communicate with inverter, the inverter will stop working and report fault.

Signal island mode: If "Signal island mode" is checked and When inverter is in off-grid mode, the relay on the Neutral line -- (load port N line) will switch ON then the N line (load port N line) will bind to inverter ground.

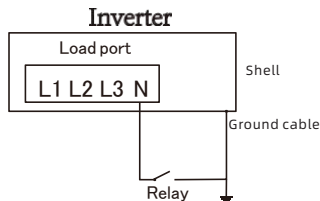

Asymmetric phase feeding: If it was checked, the inverter will take power from the grid balance of on each phase (L1/L2/L3) when needed.

Advanced Function

DC 1 for WindTurbine DC 2 for WindTurbine

V1	90V	0.0A	V7	210V	9.0A
V2	110V	1.5A	V8	230V	10.5A
V3	130V	3.0A	V9	250V	12.0A
V4	150V	4.5A	V10	270V	13.5A
V5	170V	6.0A	V11	290V	15.0A
V6	190V	7.5A	V12	310V	16.5A

Wind Set2

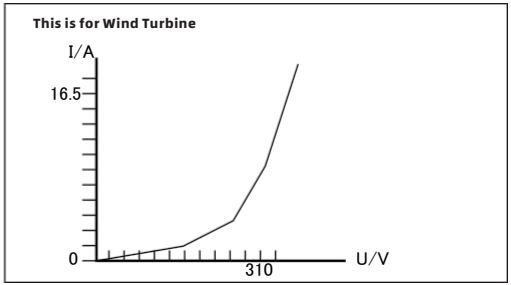

Advanced Function

Parallel Modbus SN: 00

Master

Slave

EX_Meter For CT Meter Select: CHNT, Eastron

Paral. Set3

Ex_Meter For CT: when using zero-export to CT mode, the hybrid inverter can select EX_Meter For CT function and use the different meters.e.g.CHNT and Eastron.

5.11 Device Info Setup Menu

Device Info

SUN-12K InverterID:2102199870 Flash

HMI: Ver 1001-8010 MAIN:Ver2002-1046-1707

Alarms Code	Occurred
F13 Grid_Mode_changed	2021-06-11 13:17
F23 Tz_GFCL_OC_Fault	2021-06-11 08:23
F13 Grid_Mode_changed	2021-06-11 08:21
F56 DC_VoltLow_Fault	2021-06-10 13:05

Device Info

This page show Inverter ID, Inverter version and alarm codes.

HMI: LCD version

MAIN: Control board FW version

6. Mode Mode I: Basic

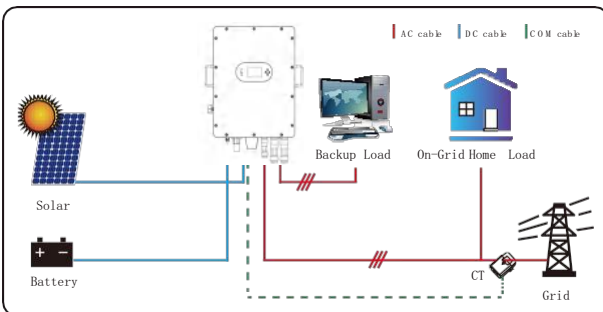

Mode II: With Generator

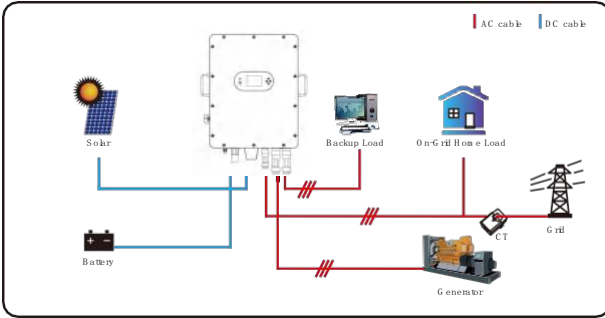

Mode III: With Smart-Load

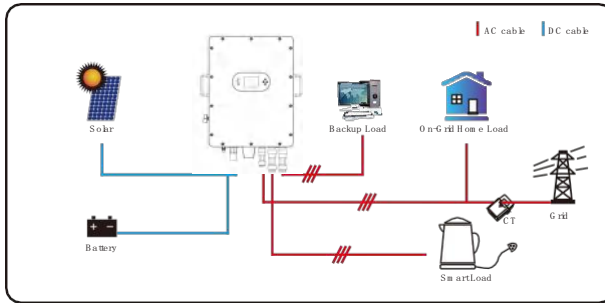

Mode IV: AC Couple

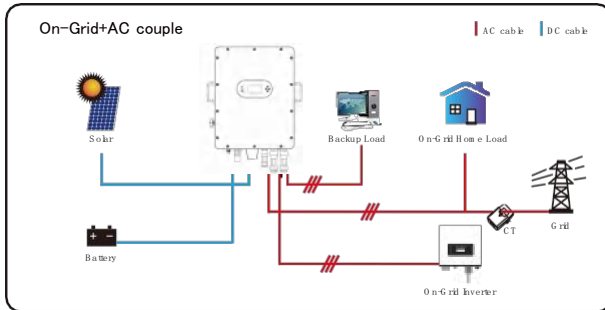

The 1st priority power of the system is always the PV power, then 2nd and 3rd priority power will be the battery bank or grid according to the settings. The last power backup will be the Generator if it is available.

7. Limitation of Liability

In addition to the product warranty described above, the state and local laws and regulations provide financial compensation for the product's power connection (including violation of implied terms and warranties). The company hereby declares that the terms and conditions of the product and the policy cannot and can not legally exclude all liability within a limited scope.

Error code	Description	Solutions
F01	DC input polarity reverse fault	<ol style="list-style-type: none"> 1, Check the PV input polarity 2, Seek help from us, if can not go back to normal state.
F07	DC_START_Failure	<ol style="list-style-type: none"> 1, The BUS voltage can't be built from PV or battery. 2, Restart the inverter, if the fault still exists, please contact us for help
F13	working mode change	<ol style="list-style-type: none"> 1. When the grid type and frequency changed it will report F13 2. When the battery mode was changed to "No battery" mode, it will report F13; 3. For some old FW version, it will report F13 when the system work mode changed; 4, Generally, it will disappear automatically when shows F13; 5. If still same, and turn off the DC switch and AC switch and wait for one minute and then turn on the DC/AC switch; 6. Seek help from us, if can not go back to normal state.
F15	AC over current fault of software	<p>AC side over current fault</p> <ol style="list-style-type: none"> 1. Please check whether the backup load power and common load power are within the range; 2. Restart and check whether it is in normal 3. Seek help from us, if can not go back to normal state
F16	AC leakage current fault	<p>Leakage current fault</p> <ol style="list-style-type: none"> 1, Check the PV side cable ground connection 2, Restart the system 2-3 times 3, if the fault still existing, please contact us for help
F18	AC over current fault of hardware	<p>AC side over current fault</p> <ol style="list-style-type: none"> 1. Please check whether the backup load power and common load power are within the range; 2. Restart and check whether it is in normal; 3. Seek help from us, if cannot go back to normal state.
F16	DC over current fault of the hardware	<p>Dc side over current fault</p> <ol style="list-style-type: none"> 1. Check PV module connect and battery connect; 2. When in the off-grid mode, the inverter startup with big power load, it may report F20. Please reduce the load power connected; 3. Turn off the DC switch and AC switch and then wait one minute, then turn on the DC/AC switch again; 4. Seek help from us, if can not go back to normal state.

Error code	Description	Solutions
F21	Tz_HV_Overcurr_fault	BUS over current. 1. Check the PV input current and battery current setting 2. Restart the system 2~3 times. 3. If the fault still exists, please contact us for help
F22	Tz_EmergStop_Fault	Remotely shutdown 1, it tells the inverter is remotely controlled.
F23	Tz_GFCI_OC_current is transient over current	Leakage current fault 1. Check PV side cable ground connection 2. Restart the system 2~3 times. 3. If the fault still exists, please contact us for help.
F23	DC insulation failure	PV isolation resistance is too low 1. Check the connection of PV panels and inverter is firmly and correctly; 2. Check whether the PE cable of inverter is connected to ground; 3. Seek help from us, if can not go back to normal state.
F26	The DC busbar is unbalanced	1. Please wait for a while and check whether it is normal; 2. When the load power of 3 phases is big different, it will report the F26. 3. When there's DC leakage current, it will report F26 4. Restart the system 2~3 times. 5. Seek help from us, if can not go back to normal state.
F29	Parallel CAN Bus fault	1. When in parallel mode, check the parallel communication cable connection and hybrid inverter communication address setting; 2. During the parallel system startup period, inverters will report F29. But when all inverters are in ON status, it will disappear automatically; 3. If the fault still exists, please contact us for help.
F34	AC Over current fault	1, Check the backup load connected, make sure it is in allowed power range 2, If the fault still exists, please contact us for help
F41	Parallel system stop	1, Check the hybrid inverter work status. If there's 1 pcs hybrid inverter shutdown, all hybrid inverters will report F41 fault. 2, If the fault still exists, please contact us for help
F42	AC line low voltage	Grid voltage fault 1. Check the AC voltage is in the range of standard voltage specification; 2. Check whether grid AC cables are firmly and correctly connected; 3. Seek help from us, if can not go back to normal state.

Error code	Description	Solutions
F21	Tz_HV_Overcurr_fault	<ol style="list-style-type: none"> 1, Please check each battery status, such as voltage/ SOC and parameters etc., and make sure all the parameters are same. 2, If the fault still exists, please contact us for help
F47	AC over frequency	<p>Grid frequency out of range</p> <ol style="list-style-type: none"> 1. Check the frequency is in the range of specification or not; 2. Check whether AC cables are firmly and correctly connected; 3. Seek help from us, if can not go back to normal state.
F48	AC lower frequency	<p>Grid frequency out of range</p> <ol style="list-style-type: none"> 1. Check the frequency is in the range of specification or not; 2. Check whether AC cables are firmly and correctly connected; 3. Seek help from us, if can not go back to normal state.
F55	DC busbar voltage is too high	<p>BUS voltage is too high</p> <ol style="list-style-type: none"> 1. Check whether battery voltage is too high; 2. check the PV input voltage, make sure it is within the allowed range; 3. Seek help from us, if can not go back to normal state.
F56	DC busbar voltage is too low	<p>Battery voltage low</p> <ol style="list-style-type: none"> 1. Check whether battery voltage is too low; 2. If the battery voltage is too low, using PV or grid to charge the battery; 3. Seek help from us, if can not go back to normal state.
F58	BMS communication fault	<ol style="list-style-type: none"> 1, it tells the communication between hybrid inverter and battery BMS disconnected when "BMS_Err-Stop" is active" 2, if don't want to see this happen, you can disable "BMS_Err-Stop" item on the LCD. 3, if the fault still exists, please contact us for help
F62	DRMs0_stop	<ol style="list-style-type: none"> 1, the DRM function is for Australia market only. 2, Check the DRM function is active or not 3, Seek help from us, if can not go back to normal state after restart the system
F63	ARC fault	<ol style="list-style-type: none"> 1. ARC fault detection is only for US market; 2. Check PV module cable connection and clear the fault; 3. Seek help from us, if can not go back to normal state
F64	Heat sink high temperature failure	<p>Heat sink temperature is too high</p> <ol style="list-style-type: none"> 1. Check whether the work environment temperature is too high; 2. Turn off the inverter for 10mins and restart; 3. Seek help from us, if can not go back to normal state.

Chart 7-1 Fault information

Under the guidance of our company, customers return our products so that our company can provide service of maintenance or replacement of products of the same value. Customers need to pay the necessary freight and other related costs. Any replacement or repair of the product will cover the remaining warranty period of the product. If any part of the product or product is replaced by the company itself during the warranty period, all rights and interests of the replacement product or component belong to the company.

Factory warranty does not include damage due to the following reasons:

Factory warranty does not include damage due to the following reasons:

- Damage during transportation of equipment;
- Damage caused by incorrect installation or commissioning;
- Damage caused by failure to comply with operation instructions, installation instructions or maintenance instructions;
- Damage caused by attempts to modify, alter or repair products;
- Damage caused by incorrect use or operation;
- Damage caused by insufficient ventilation of equipment;
- Damage caused by failure to comply with applicable safety standards or regulations;
- Damage caused by natural disasters or force majeure (e.g. floods, lightning, overvoltage, storms, fires, etc.)

In addition, normal wear or any other failure will not affect the basic operation of the product. Any external scratches, stains or natural mechanical wear does not represent a defect in the product.

9. Datasheet

Model	PD0060G-TPM-EU	PD0080G-TPM-EU	PD0100G-TPM-EU	PD0120G-TPM-EU
PV String Input Data				
Max. DC Input Power (W)	7800	10400	13000	15600
Rated PV Input Voltage (V)	550 (160-800)			
Start-up Voltage (V)	160			
MPPT Voltage Range (V)	200-650			
Full Load DC Voltage Range (V)	350-650			
PV Input Current (A)	13+13		26+13	
Max. PV Isc (A)	17+17		34+17	
No. of MPP Trackers	2			
No. of Strings per MPP Tracker	1+1		2+2	
AC Output Data				
Rated AC Output Active Power (W)	6000	8000	10000	12000
Max AC Output Active Power (W)	6600	8800	11000	13200
AC Output Rated Current (A)	9.12	12.16	15.21	18.25
Max AC Output Current (A)	10.03	13.38	16.73	20.07
Max. Three-phase Unbalanced Output Current(A)	13.63	18.18	22.72	27.27
Max. Output short circuit current(A)	75			
Max. Continuous AC Passthrough (A)	45			
Peak Power (off grid)	2 time of rated power, 10 S			
Power Factor	0.8 leading to 0.8 lagging			
Output Frequency and Voltage	50/60Hz; 3L/N/PE 220/380Vac,230/400Vac			
Grid Type	Three Phase			
Total Harmonic Distortion (THDi)	<3% (of nominal power)			
DC Current Injection	<0.5% In			
Battery Input Data				
Battery Type	Lead-acid or Lithium-ion			
Battery Voltage Range (V)	40-60			
Max. Charging Current (A)	150	190	210	240
Max. Discharging Current (A)	150	190	210	240
External Temperature Sensor	Yes			
Charging Curve	3 Stages / Equalization			
Charging Strategy for Li-Ion Battery	Self-adaption to BMS			
Efficiency				
Max. Efficiency	97.6%			
Euro Efficiency	96.5%			
MPPT Efficiency	99.9%			
Efficiency				
Anti-islanding Protection	Yes			
PV String Input Reverse Polarity Protection	Yes			
Insulation Resistor Detection	Yes			
Residual Current Monitoring Unit	Yes			
Output Over Current Protection	Yes			
Output Shorted Protection	Yes			
Surge Protection	DC Type III/AC Type III			
Over Voltage Category	DC Type II/AC Type III			

Certifications and Standards	
Grid Regulation	VDE4105, IEC61727/62116, VDE0126, AS4777.2, CEI 0 21, EN50549-1, G98, G99, C10-11, UNE217002, NBR16149/NBR16150
Safety EMC / Standard	IEC/EN 61000-6-1/2/3/4, IEC/EN 62109-1, IEC/EN 62109-2
Certifications and Standards	
Operating Temperature Range (°C)	-40-60°C, >45°C Derating
Cooling	Smart Cooling
Noise (dB)	≤45 dB
Communication with BMS	RS485; CAN
Monitor mode	WiFi, APP
Weight (kg)	33.6
Cabinet Size (W x H x D mm)	422x702x281 mm (Excluding Connectors and Brackets)
Protection Degree	Ip65
Installation Style	Wall-mounted
Warranty	5 Years (10Years Optional)

9. Appendix I

Definition of RJ45 Port Pin for BMS

No.	RS485 Pin
1	485_B
2	485_A
3	--
4	CAN-H
5	CAN-L
6	GND_485
7	485_A
8	485_B

BMS Port



Definition of RJ45 Port Pin for Meter-485

No.	Meter-485Pin
1	METER-485-B
2	METER-485-A
3	COM-GND
4	METER-485-B
5	METER-485-A
6	COM-GND
7	METER-485-A
8	METER-485-B

Meter-485 Port



Definition of RJ45 Port Pin of "Modbus port" for remotely monitoring

No.	Modbus port
1	485_B
2	485_A
3	GND_485
4	--
5	--
6	GND_485
7	485_A
8	485_B

Modbus port

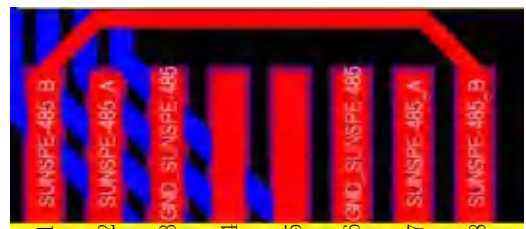

Note :forsome hardware versionsthisport isuseless.

RS232

No.	WIFI/RS232
1	
2	TX
3	RX
4	
5	D-GND
6	
7	
8	
9	12Vdc

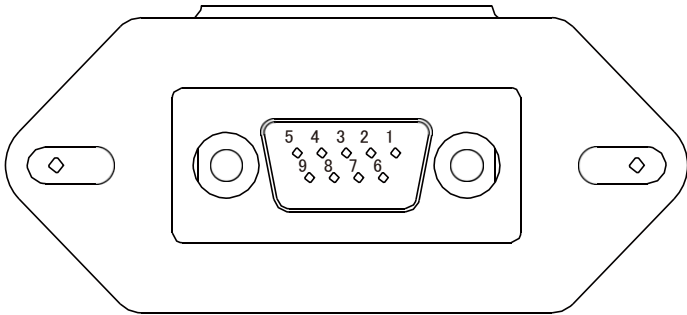

WIFI/RS232

This RS232 port is used to connect the wifi datalogger

10. Appendix II

1. Split Core Current Transformer (CT) dimension: (mm)
2. Secondary output cable length is 4m.

